

Gas Burners



RS 28/M - 38/M - 50/M

Low-High-Low or Modulating Operation

CONTENTS

TECHNICAL DATA	page 3
Burner models	3
Accessories	3
Burner description	4
Packaging - Weight	4
Max. dimensions	4
Standard equipment	4
Firing rates	5
Minimum furnace dimensions	5
Gas pressure	6
INSTALLATION	7
Boiler plate	7
Blast tube length	7
Securing the burner to the boiler	7
Ignition pilot adjustment	7
Combustion head adjustment	8
Gas piping	9
Adjustments before first firing	10
Servomotor	10
Burner starting	10
Burner firing	10
Burner calibration:	11
1 - Firing output	11
2 - Maximum output	11
3 - Minimum output	12
4 - Intermediates outputs	12
5 - Air pressure switch	13
6 - Low gas pressure switch	13
Flame present check	13
Maintenance	14
Factory wiring diagram - burner mounted LFL	15
Field wiring diagram - burner mounted LFL	16
Factory wiring - remote panel	17
Appendix - Burner firing rates according to air density	18
Siemens LFL control sequence of operations	19
Siemens LFL control troubleshooting guide	20
Start up report	21

N.B.

Figures mentioned in the text are identified as follows:

- 1)(A) = part 1 of figure A, same page as text;
- 1)(A)p.4 = part 1 of figure A, page number 4.

WARNING

If you smell gas:

- Do not touch any electrical items.
- Open all windows.
- Close all gas supply valves.
- Contact your local gas authority immediately.

Do not store flammable or hazardous materials in the vicinity of fuel burning appliances.

Improper installation, adjustment, alteration, service or maintenance can cause property damage, personal injury or death. Refer to this manual for instructional or additional information. Consult a certified installer, service representative or the gas supplier for further assistance.

Burner shall be installed in accordance with manufacturers requirements as outlined in this manual, local codes and authorities having jurisdiction.

TECHNICAL DATA

Model			RS 28/M	RS 38/M	RS 38/M	RS 50/M
Output (1)	MAX.	MBtu/hr kW	617 - 1232 181 - 361	880 - 1665 258 - 488	880 - 1665 258 - 488	1099 - 2201 322 - 645
	MIN.	MBtu/hr kW	198 58	266 78	266 78	321 94
Fuel			Natural or propane gas			
- Max delivery		SCFH	1232	1665	1665	2201
- Pressure at maximum delivery (2) natural gas		" WC	2.95	2.6	2.6	2.83
Operation			Low - high-low or modulating			
Standard application			Boilers: water, steam, thermal oil			
Ambient temperature		°F	32 - 104 (0 - 40 °C)			
Combustion air temperature		°F max	140 (60 °C)			
Main power supply (+/-10%)		V/Ph/Hz	120/1/60		208-230/460/575/3/60	
Fan motor		rpm W - HP V A	3400 370 - 0.5 120 5.2		3400 550 - 0.75 208-230/460/575 3.2 - 1.6 - 1.3	
Motor capacitor		µV	45			
Ignition transformer		V1 - V2 I1 - I2	120 V - 1 x 7 kV 1.6 A - 23 mA			
Electrical power consumption		W max	600		750	
Electrical protection			NEMA 1			
Noise levels (3)		dBA	68	70	70	72

(1) Reference conditions: Ambient temperature 68 °F (20 °C) - Barometric pressure 394" WC - Altitude 329 ft.

(2) Pressure at test point 8)(A)p.4, with zero pressure in the combustion chamber, with open gas ring 2)(B)p.8 at maximum burner output

(3) Sound pressure measured in manufacturer's combustion laboratory, with burner operating on test boiler and at maximum rated output.

Burner models designation:

Model	Code	Voltage	Flame safeguard
RS 28/M	C9521300 (3781070)	120/1/60	Burner mounted
	C9621300 (3781072)	120/1/60	Remote panel
RS 38/M	C9522300 (3781270)	120/1/60	Burner mounted
	C9622300 (3781272)	120/1/60	Remote panel
	C9522350 (3781470)	208-230/460/3/60	Burner mounted
	C9522351 (3781470)	575/3/60	Burner mounted
	C9622350 (3781472)	208-230/460/3/60	Remote panel
	C9622351 (3781472)	575/3/60	Remote panel
RS 50/M	C9523300 (3781670)	208-230/460/3/60	Burner mounted
	C9523301 (3781670)	575/3/60	Burner mounted
	C9623300 (3781672)	208-230/460/3/60	Remote panel
	C9623301 (3781672)	575/3/60	Remote panel

ACCESSORIES (optional):

- **Kit for LPG operation:** The kit allows the RS 28-38-50/M burners to operate on LPG.

Burner		RS 28/M	RS 38/M	RS 50/M
Output	MBtu/hr	358 - 1232	437 - 1665	549 - 1986
Blast tube length	inch	8 ¹ / ₂ " 13 ¹³ / ₁₆ "	8 ¹ / ₂ " 13 ¹³ / ₁₆ "	8 ¹ / ₂ " 13 ¹³ / ₁₆ "
Code		3010270	3010271	3010272

- **Modulating control kit:** Under modulating operation, the burner automatically adapts to one of an infinite number of firing rates between the low and high flame output position, thus ensuring stable operating conditions in terms of temperature or pressure. Two components should be ordered: • Modulating control to install to the burner; • probe to install to the boiler.

Parameter to be checked	Range	Probe		Modulating control	
		Type	Code	Type	Code
Temperature	- 212...+ 932 °F (- 100...+ 500 °C)	PT 100	3010110		
Pressure	0...36.3 PSI (0...2.5 bar)	Output probe	3010213	RWF40	3010212
	0...232 PSI (0...16 bar)	4...20 mA	3010214		

- **Gas train according to UL Standards:** see page 9.

Important:

The installer is responsible for the supply and installation of any required safety device(s) not indicated in this manual.

Kit for lengthening the combustion head

L = Standard length

L1 = Length obtainable with the kit

COD. 3010256	L = 8 ¹ / ₂ "	L1 = 13 ¹³ / ₁₆ "	• RS 28/M
COD. 3010257	L = 8 ¹ / ₂ "	L1 = 13 ¹³ / ₁₆ "	• RS 38/M
COD. 3010258	L = 8 ¹ / ₂ "	L1 = 13 ¹³ / ₁₆ "	• RS 50/M

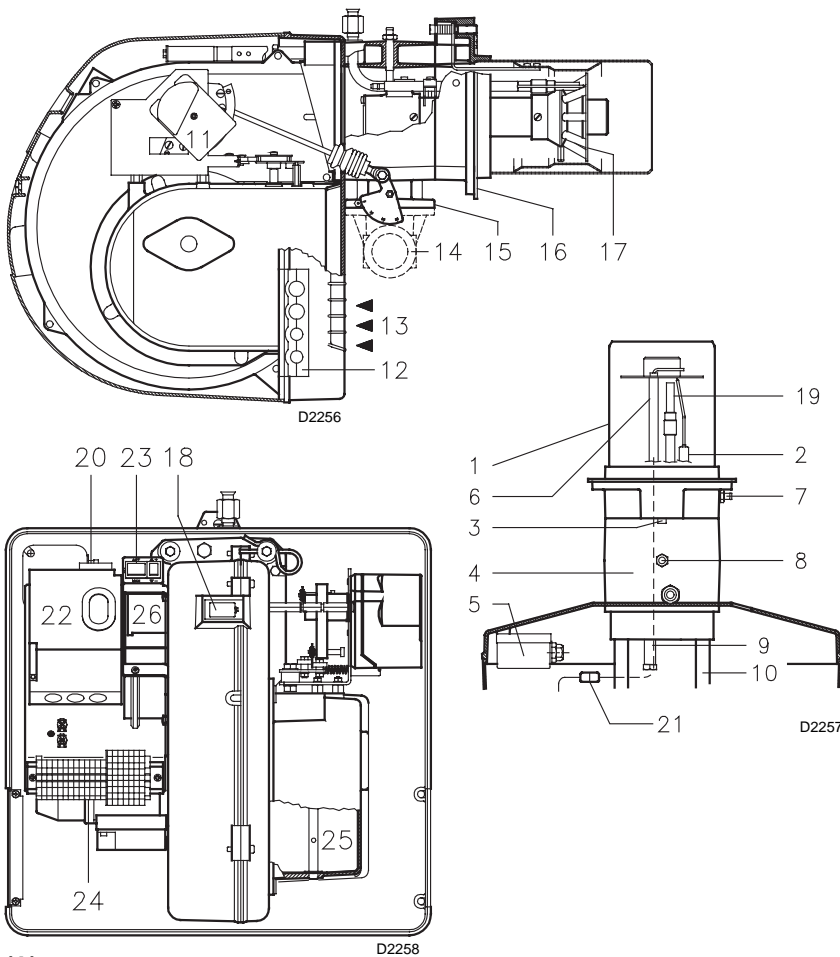

BURNER DESCRIPTION (A)

- 1 Combustion head
- 2 Ignition electrode
- 3 Screw for combustion head adjustment
- 4 Sleeve
- 5 Low air pressure switch (differential operating type)
- 6 Flame sensor probe (flame rod)
- 7 Air pressure test point
- 8 Gas pressure test point and head fixing screw
- 9 Screws securing fan to sleeve
- 10 Slide bars for opening the burner and inspecting the combustion head
- 11 Servomotor controlling the gas butterfly valve and air damper (by means of a variable profile cam mechanism).
When the burner is not operating the air damper is fully closed in order to reduce heat loss.
- 12 Plate with four hole knock-outs for electrical cable routing
- 13 Air inlet to fan
- 14 Gas input connection
- 15 Gas butterfly valve
- 16 Boiler mounting flange
- 17 Flame stability disk
- 18 Flame inspection window
- 19 Ignition pilot
- 20 Motor contactor and thermal overload reset button (RS 38 - 50 three-phase)
- 21 Plug-socket on flame rod probe cable
- 22 Flame safeguard
- 23 Power switch for different operations:
automatic - manual - off
Switch for:
manual modulation of servomotor
- 24 Burner terminal strip
- 25 Air damper
- 26 Bracket for mounting the PID modulating controller RWF40 (optional)

(A)

inch	A	B	C	lbs
RS 28/M	39 ^{31/32} "	24 ^{13/16} "	19 ^{11/16} "	84
RS 38/M	39 ^{31/32} "	24 ^{13/16} "	19 ^{11/16} "	88
RS 50/M	39 ^{31/32} "	24 ^{13/16} "	19 ^{11/16} "	91

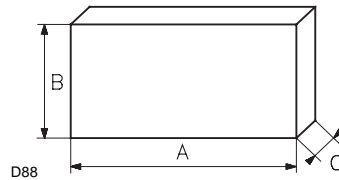

(B)

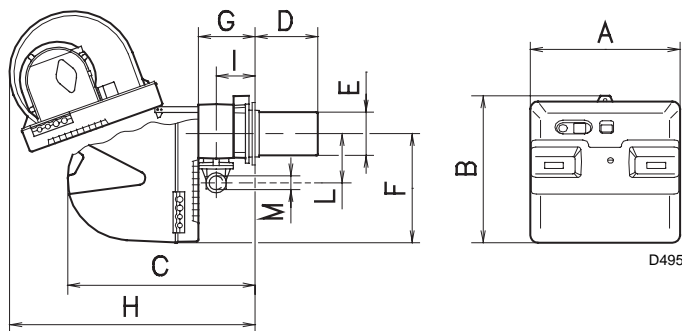

RS	A	B	C	D (1)	E	F	G	H	I	L	M
28	18 ^{23/32} "	18 ^{21/32} "	22 ^{13/16} "	8 1/2"-13 ^{13/16} "	5 1/2"	13 ^{27/32} "	6 ^{7/16} "	31 ^{7/8} "	4 1/4"	6 ^{5/8} "	11 1/2"
38	18 ^{23/32} "	18 ^{21/32} "	22 ^{13/16} "	8 1/2"-13 ^{13/16} "	5 1/2"	13 ^{27/32} "	6 ^{7/16} "	31 ^{7/8} "	4 1/4"	6 ^{5/8} "	11 1/2"
50	18 ^{23/32} "	18 ^{21/32} "	22 ^{13/16} "	8 1/2"-13 ^{13/16} "	5 ^{31/32} "	13 ^{27/32} "	6 ^{7/16} "	31 ^{7/8} "	4 1/4"	6 ^{5/8} "	11 1/2"

(1) Blast tube: short - long (with kit)

(C)

Two types of burner failure may occur:

- **FLAME SAFEGUARD LOCK-OUT:**
if the flame relay 22(A) pushbutton lights up, it indicates that the burner is in lock-out.
To reset, press the pushbutton.
- **MOTOR TRIP (RS 38 - 50 three-phase):**
release by pressing the pushbutton on thermal overload 20(A).

PACKAGING - WEIGHT (B) - Approximate measurements

- The burners are shipped in cardboard boxes with the maximum dimensions shown in Table (B).
- The weight of the burner complete with packaging is indicated in table (B).

MAX. DIMENSIONS (C)

Approximate measurements
The maximum dimensions of the burners are given in (C).

Note that if you need to examine the combustion head, the burner must be pulled backward on the slide bars and turned upward.

The maximum dimension of the burner, without the cover, when open is give by measurement H.

STANDARD EQUIPMENT

- 1 - Gas train flange
- 1 - Flange gasket
- 4 - Flange fixing screws
- 1 - Burner head gasket
- 4 - Screws to secure the burner flange to the boiler:
3/8 W x 1"
- 1 - Instruction booklet
- 1 - Spare parts list

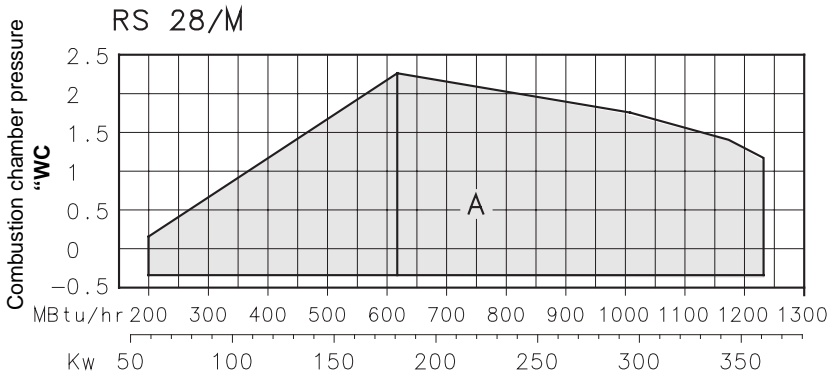

FIRING RATES (A)

During operation, burner output varies between:

- **MAXIMUM OUTPUT**, selected within area A,
- **MINIMUM OUTPUT**, which must not be lower than the minimum limit in the diagram.

RS 28/M	= 198 MBtu/hr	58 kW
RS 38/M	= 266 MBtu/hr	78 kW
RS 50/M	= 321 MBtu/hr	94 kW

Important:

The FIRING RATE value range has been obtained considering an ambient temperature of 68 °F (20 °C), and an atmospheric pressure of 394" WC and with the combustion head adjusted as shown on page 8.

Note:

The FIRING RATE areas given in figure (A) have been reduced by 10% with respect to the maximum range that can be reached.

Consult Appendix on page 18 for operation at different surrounding temperatures and/or altitudes.

MINIMUM FURNACE DIMENSIONS (B)

The firing rates were set in relation to certified test boilers.

Figure (B) indicates the diameter and length of the test combustion chamber.

Example:

output 1388 MBtu/hr:
diameter 20 inch - length 4.9 ft.

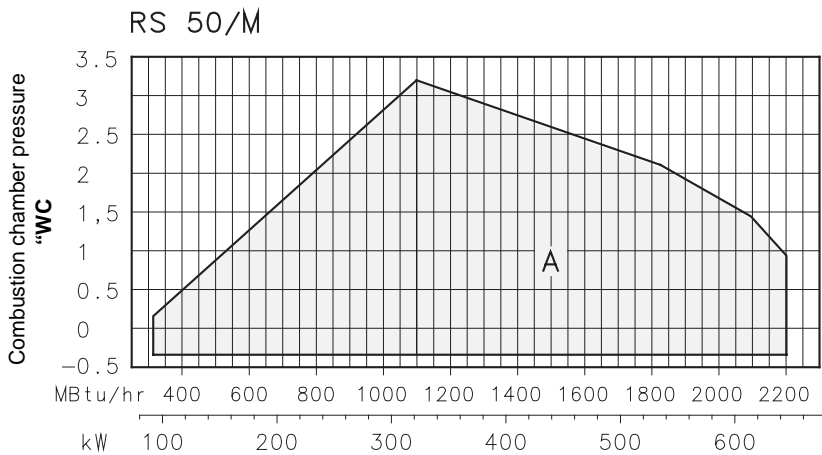
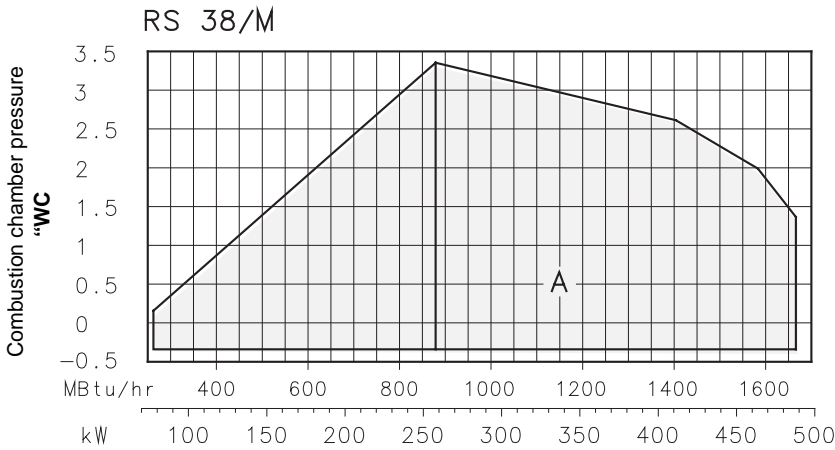

(A)

D2259

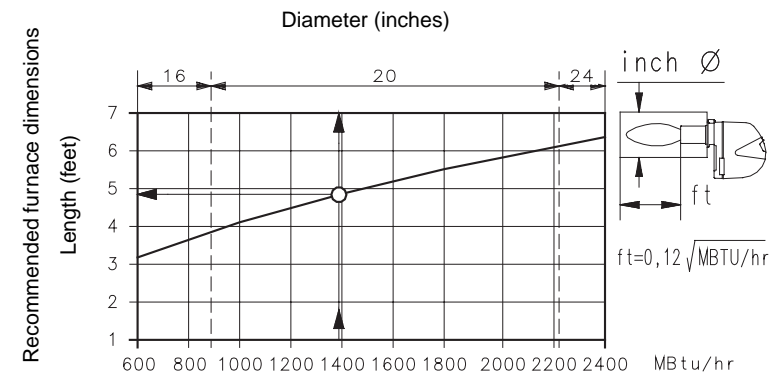

(B)

D2918

RS 28/M

MBtu/hr	kW	Δp (" WC)		
		1		2
		A	B	
624	183	0.98	0.98	0.039
699	205	1.22	1.3	0.039
795	233	1.57	1.69	0.039
891	261	1.85	2.05	0.079
986	289	2.17	2.28	0.079
1078	316	2.48	2.68	0.12
1174	344	2.76	3.07	0.12
1232	361	2.95	3.58	0.12

RS 38/M

MBtu/hr	kW	Δp (" WC)		
		1		2
		A	B	
870	255	1.02	1.02	0.079
979	287	1.22	1.38	0.079
1099	322	1.46	1.77	0.12
1211	355	1.69	2.28	0.12
1327	389	1.89	2.72	0.16
1440	422	2.13	3.11	0.16
1552	455	2.36	3.54	0.2
1665	488	2.6	4.21	0.23

RS 50/M

MBtu/hr	kW	Δp (" WC)		
		1		2
		A	B	
1099	322	0.87	0.87	0.12
1249	366	1.14	1.3	0.16
1402	411	1.42	1.61	0.2
1552	455	1.69	2.01	0.23
1706	500	1.97	2.36	0.28
1856	544	2.2	2.76	0.35
2006	588	2.48	3.15	0.39
2197	644	2.83	3.78	0.47

(A)

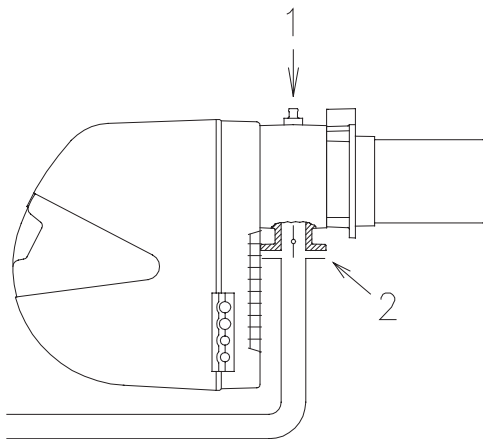

(B)

GAS PRESSURE

The adjacent tables are used to calculate manifold pressure taking into account combustion chamber pressure.

Column 1

Pressure loss at combustion head.

Gas pressure measured at test point 1)(B), with:

- Combustion chamber at 0" WC
- Burner operating at maximum output
- **A** = Gas ring 2)(B)p.8 adjusted as indicated in diagram (C)p. 8.
- **B** = Gas ring 2)(B) adjusted to zero.

Column 2

Pressure loss at gas butterfly valve 2)(B) with maximum opening: 90°.

Calculate the approximate maximum output of the burner as follows:

- subtract the combustion chamber pressure from the gas pressure measured at test point 1)(B).
- Find the nearest pressure value to your result in column 1A or B of the table for the burner in question.
- Read off the corresponding output on the left.

Example - RS 28/M:

- Maximum output operation
 - Natural gas
 - Gas ring 2)(B)p.8 adjusted as indicated in diagram (C)p.8.
 - Gas pressure at test point 1)(B) = 2.36" WC
 - Pressure in combustion chamber = 0.79" WC
- $$2.36 - 0.79 = 1.57" \text{ WC}$$

A maximum output of 795 MBtu/hr shown in Table RS 28/M corresponds to 1.57" WC pressure, column 1A.

This value serves as a rough guide, the effective delivery must be measured at the gas meter.

To calculate the required gas manifold pressure at test point 1)(B), set the maximum output required from the burner operation:

- find the nearest output value in the table for the burner in question.
- Read off the pressure at test point 1)(B) on the right in column 1A or B.
- Add this value to the estimated pressure in the combustion chamber.

Example - RS 28/M:

- Required burner maximum output operation: 795 MBtu/hr
 - Natural gas
 - Gas ring 2)(B)p.8 adjusted as diagram (C)p.8.
 - Gas pressure at burner output of 795 MBtu/hr, taken from table RS 28, column 1A = 1.57" WC
 - Pressure in combustion chamber = 0.79" WC
- $$1.57 + 0.79 = 2.36" \text{ WC}$$
- pressure required at test point 1)(B).

INSTALLATION

BURNER MOUNTING (A)

Drill the combustion chamber mounting plate as shown in (A).

The position of the threaded holes can be marked using the head gasket supplied with the burner.

BLAST TUBE LENGTH (B)

The length of the blast tube must be selected according to the indications provided by the manufacturer of the boiler, and it must be greater than the thickness of the boiler door complete with its insulation. The range of lengths available, L (inches), is as follows:

Blast tube 10):	RS 28/M	RS 38/M	RS 50/M
• short	8 1/2"	8 1/2"	8 1/2"
• long	13 13/16"	13 13/16"	13 13/16"

For boilers with front flue passes 13) or flame inversion chambers, protective insulation material 11) must be inserted between the boiler refractory 12) and the blast tube 10).

This protective insulation must not compromise the extraction of the blast tube.

For boilers having a water-cooled front, the insulation 11)-12)(B) is not required unless it is required by the boiler manufacturer.

SECURING THE BURNER TO THE BOILER (B)

Before securing the burner to the boiler, check through the blast tube opening to make sure that the flame sensor probe is correctly set in position, as shown in (C).

Now detach the combustion head from the burner, fig.(B):

- Remove screw 14) and withdraw the cover 15).
- Disengage the swivel coupling 4) from the graduated sector 5).
- Remove the screws 2) from the slide bars 3)
- Remove screw 1) and pull the burner back on slide bars 3) by about 4".

Disconnect the wires from the probe and the electrode and then pull the burner completely off the slide bars, after removing the split pin from the slide bar 3).

Secure the flange 9)(B) to the boiler plate, inserting the head gasket 6)(B). Use the 4 screws, also supplied with the unit, after first protecting the thread with an anti-seize product.

The seal between burner and boiler must be airtight.

If you noticed any irregularities in the positions of the probe or ignition electrode during the check mentioned above, remove screw 1)(D), extract the internal part 2)(D) of the head and set up the two components correctly.

IGNITION PILOT ADJUSTMENT

Place the pilot and electrode as shown in fig. (C).

The pilot works correctly at pressures ranging from 5 - 12" WC.

Important

To set the pilot without main burner operation, proceed as follows:

- Move the jumper from terminals "30-V11" to terminals "30-VP", as given in fig. (E), this way the main valve is not energized.
- With the burner in the manual position, hold the air damper in the minimum position and make the setting.
- When the setting is correct, replace the jumper on "30-V11".

inch	A	B	C
RS 28/M	6 ⁹ / ₃₂ "	8 ¹³ / ₁₆ "	3/8 W
RS 38/M	6 ⁹ / ₃₂ "	8 ¹³ / ₁₆ "	3/8 W
RS 50/M	6 ⁹ / ₃₂ "	8 ¹³ / ₁₆ "	3/8 W

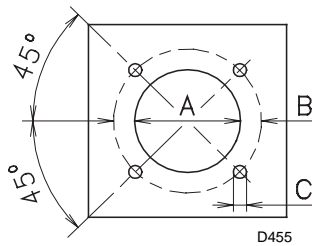

D455

(A)

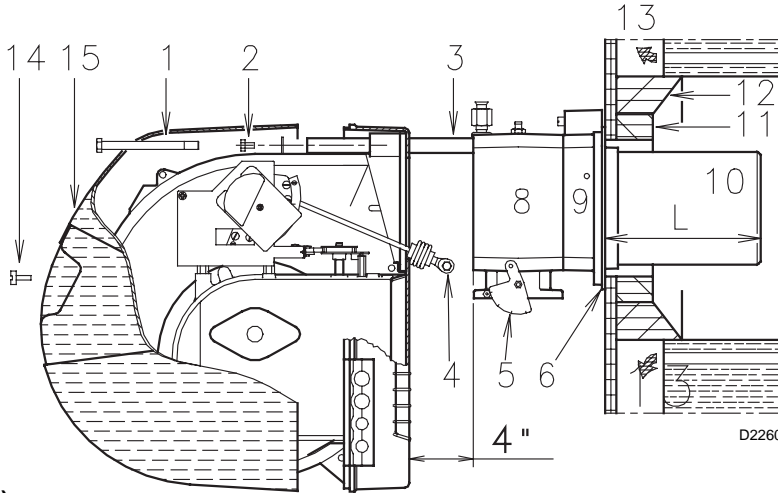

D2260

(B)

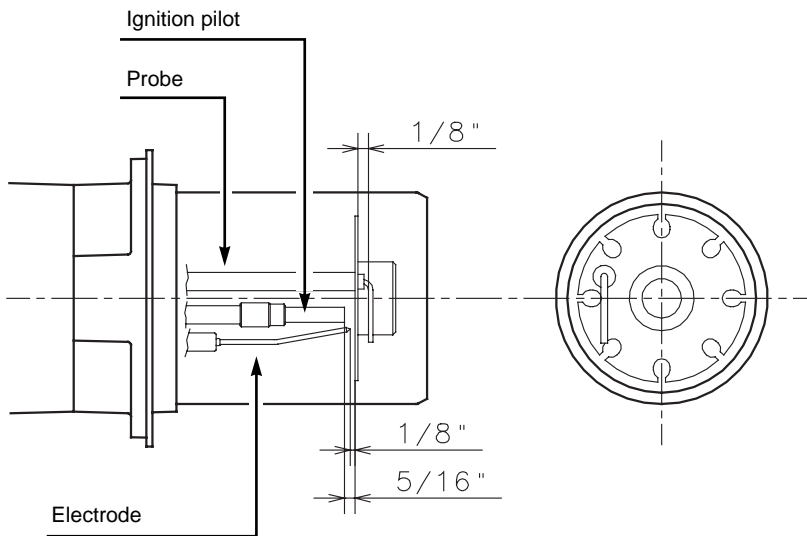

D2261

(C)

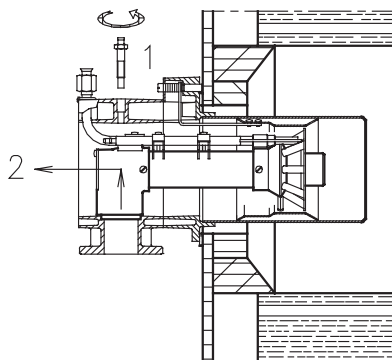

D2292

(D)

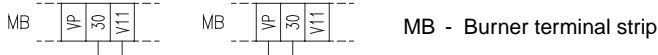

(E)

D2317

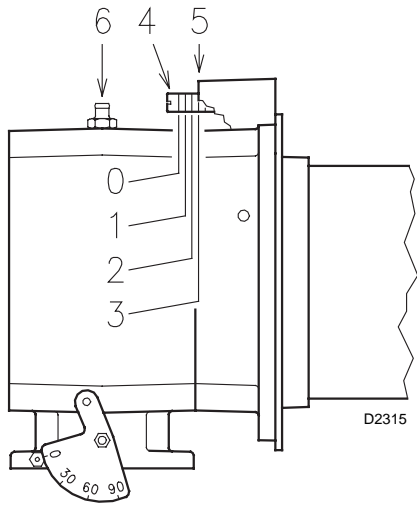

(A)

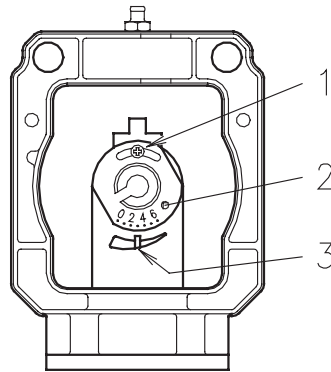

(B)

Notches (Air = Gas)

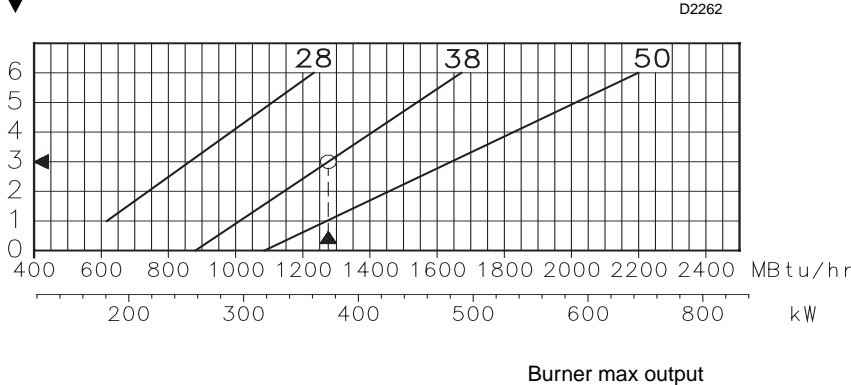

(C)

MODULATION MINIMUM OUTPUT: when the MIN output is within the value range given below, the gas ring 2)(B) is adjusted to zero.

RS 28/M	198 - 280 MBtu/hr	58 - 82 kW
RS 38/M	266 - 375 MBtu/hr	78 - 110 kW
RS 50/M	321 - 488 MBtu/hr	94 - 143 kW

(D)

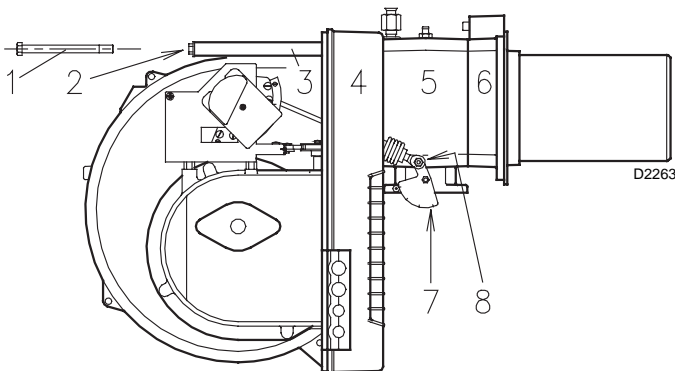

(E)

COMBUSTION HEAD ADJUSTMENT

Installation operations are now at the stage where the blast tube and sleeve are secured to the boiler as shown in fig. (A).

There are two possible cases:

A - The MIN burner output is not in the values of table (D).

In diagram (C), depending on the MAX output, find the notch to use for adjusting the air and the gas, and then proceed as follows:

Air adjustment (A)

Turn screw 4)(A) until the notch identified is aligned with the front surface 5)(A) of the flange.

Gas adjustment (B)

Loosen screw 1)(B) and turn ring 2) until the notch identified is aligned with index 3).

Tighten the screw 1) fully down.

Example:

the burner RS 38/M varies its output between: MIN = 378.7 and MAX = 1288 MBtu/hr.

The MIN output of 378.7 MBtu/hr is not found in the values of table (D) and therefore diagram (C) is valid, from which it results that for a MAX output of 1288 MBtu/hr the gas and air adjustments are done on notch 3, as in fig. (A) and (B).

In this case the pressure load loss of the combustion head is given by column 1A page 6.

Note

Diagram (C) shows the ideal settings for the ring 2)(B). If the gas supply pressure is too low to reach the max output operation pressure indicated on page 6, and if the ring 2)(B) is not fully open, it can be opened wider by 1 or 2 notches.

Continuing with the previous example, page 6 indicates that for burner RS 38/M with output of 1288 MBtu/hr a pressure of approximately 1.81" WC is necessary at test point 6)(A). If this pressure cannot be reached, open the ring 2)(B) to notch 4 or 5.

Make sure that the combustion characteristics are satisfactory and free of pulsations.

B - The MIN burner output is found in the values of the table (D).

Air adjustment

The same as the previous case: follow diagram (C).

Gas adjustment

The gas ring 2)(B) is always adjusted to position 0, irrespective of the MAX burner.

In this case the pressure load loss of the combustion heads is given by column 1B page 6.

Once you have finished setting up the head, refit the burner 4)(E) to the slide bars 3) at approximately 4" from the sleeve 5) - burner positioned as shown in fig.(B)p.7 - insert the flame rod cable and the ignition electrode cable and then slide the burner up to the sleeve so that it is positioned as shown in fig.(E).

Refit screws 2) on slide bars 3).

Secure the burner to the sleeve by tightening screw 1) and then refit the split pin into one of two slide bars 3).

Reconnect the swivel connector 8) to the graduated sector 7).

Connect gas train and pilot train as shown in fig. (A) page 9.

Important

When fitting the burner on the two slide bars, it is advisable to gently draw out the high tension cable and flame detection probe cable until they are slightly stretched.

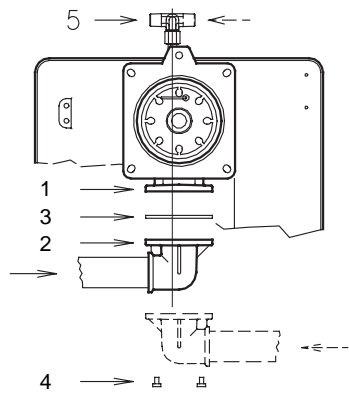

(A)

D2293

TYPICAL UL SCHEMATIC GAS PIPING

GAS PIPING

- The main gas train must be connected to the gas attachment 1)(A), using flange 2), gasket 3) and screws 4) supplied with the burner.
- The main gas train can enter the burner from the right or left side, depending on which is the most convenient, see fig.(A).
- Gas safety shut-off valves 5)-6)(B) must be as close as possible to the burner to ensure gas reaches the combustion head within the safety time range.
- The pilot gas train must be connected to the gas attachment 5)(A) and can enter the burner from the right or left side.

GAS TRAIN (B)

It must be type-approved according to required local standards and is supplied separately from the burner.

Note

See the accompanying instructions for the gas train layout.

KEY (B)

- 1 - Gas input pipe
- 2 - Manual valve
- 3 - Pressure regulator
- 4 - Low gas pressure switch
- 5 - 1st safety shut off valve
- 6 - 2nd safety shut off valve
- 7 - Standard issue burner gasket with flange
- 8 - Gas adjustment butterfly valve
- 9 - Burner

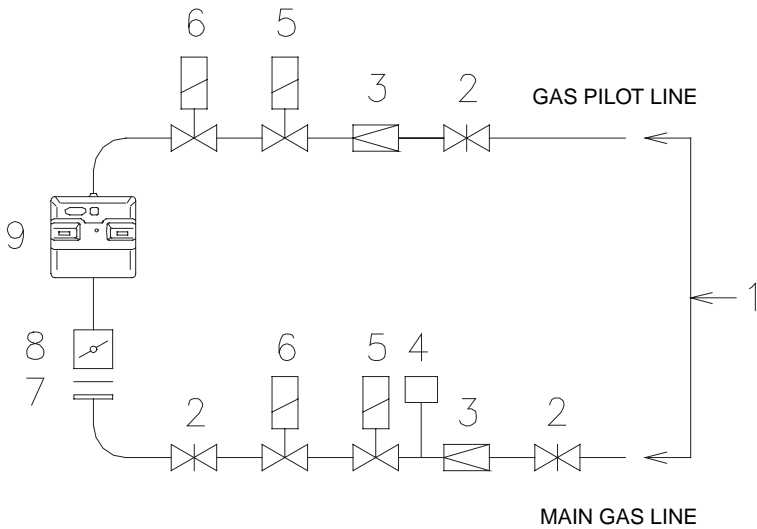

(B)

D2294

LOW GAS PRESSURE SWITCH

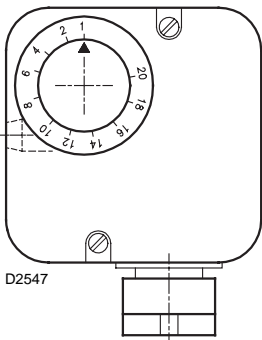

(A)

AIR PRESSURE SWITCH

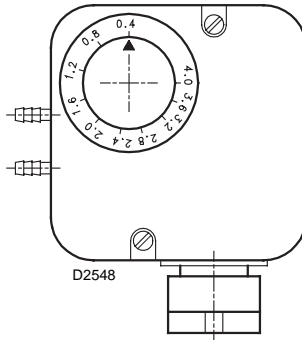

(B)

ADJUSTMENTS BEFORE FIRST FIRING

Adjustment of the combustion head, and air and gas deliveries has been illustrated on page 8.

In addition, the following adjustments must also be made:

- open manual valves on the gas train.
- Adjust the low gas pressure switch to the start of the scale (A).
- Adjust the air pressure switch to the zero position of the scale (B).
- Purge the air from the gas line.
- Fit a U-type manometer (C) to the gas pressure test point on the sleeve.

The manometer readings are used to calculate MAX. burner power using the tables on page 6.

Before starting up the burner it is good practice to adjust the gas train so that ignition takes place in conditions of maximum safety, i.e. with gas delivery at the minimum.

SERVOMOTOR (D)

The servomotor provides simultaneous adjustment of the air damper, by means of the variable profile cam, and the gas butterfly valve.

The angle of rotation of the servomotor is equal to the angle on the graduated sector controlling the gas butterfly valve. The servomotor rotates through 90 degrees in 25 seconds.

Do not alter the factory setting for the cams; simply check that they are set as indicated below:

- Red cam** : 90°
Limits rotation toward maximum position. When the burner is at max output the gas butterfly valve must be fully open: 90°.
- Blue cam** : 0°
Limits rotation toward the minimum position. When the burner is shut down the air damper and the gas butterfly valve must be closed: 0°.
- Orange cam** : 15°
Adjusts the ignition position and the MIN output.

BURNER STARTING

Close the control circuit and set switch 1)(E) to "MAN". As soon as the burner starts check the direction of rotation of the fan blade, looking through the flame inspection window 18)(A)p.4.

BURNER FIRING

Having completed the checks indicated in the previous heading, the pilot of the burner should fire. If the motor starts but the flame does not appear and the flame safeguard goes into lock-out, reset and wait for a new firing attempt.

Pilot adjustment has been illustrated on page. 7.

Having adjusted the pilot, reconnect the main valve and ignite the main flame; it might require several attempts to purge the air from the gas lines or to adjust the valve with little gas.

Once the burner has fired, now proceed with calibration operations.

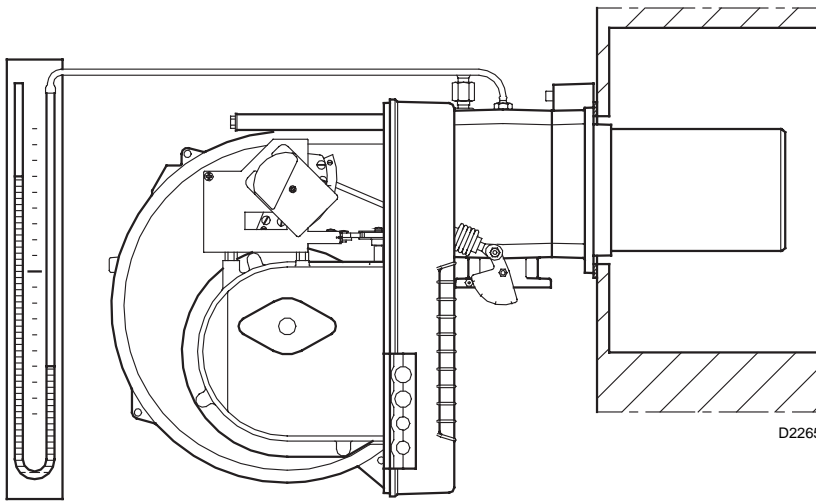

(C)

SERVOMOTOR

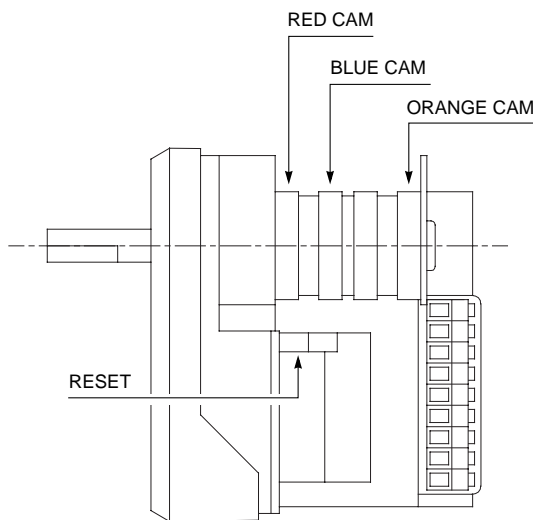

(D)

D2266

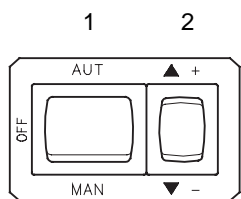

(E)

D791

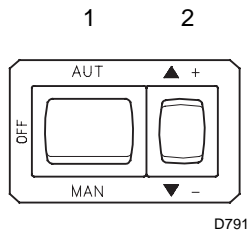

(A)

BURNER CALIBRATION

The optimum calibration of the burner requires an analysis of the flue gases at the boiler outlet.

Adjust successively:

- 1 - First firing output
- 2 - Max. burner output
- 3 - Min. burner output
- 4 - Intermediate outputs between low and high fire
- 5 - Air pressure switch
- 6 - Minimum gas pressure switch

1 - FIRING OUTPUT

Pilot adjustment has been illustrated on page. 7.

2 - MAXIMUM OUTPUT

Maximum output of the burner must be set within the firing rate range shown on page 5.

In the above instructions we left the burner running in MIN. output operation. Now press switch 2)(A) "increase output" and keep it pressed until the servomotor has opened the air damper and the gas butterfly valve to 90°.

Gas calibration

Measure the gas delivery at the meter.

A guideline indication can be calculated from the tables on page 6, simply read off the gas pressure on the U-type manometer, see fig.(C) on page 10, and follow the instructions on page 6.

- If delivery needs to be reduced, reduce outlet gas pressure and, if it is already very low, slightly close adjustment valve.
- If delivery needs to be increased, increase outlet gas pressure.

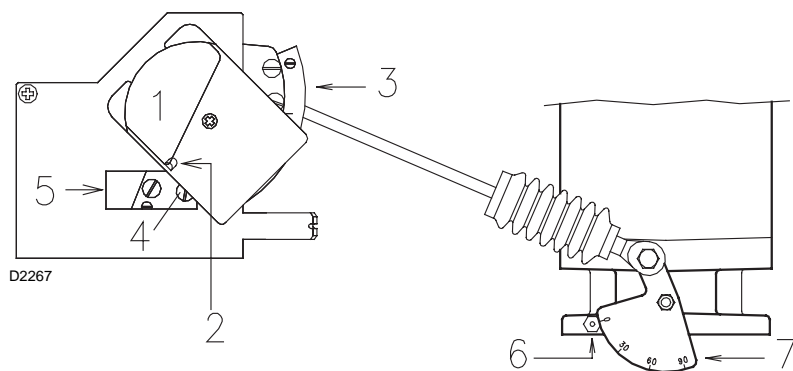

D2267

- 1 Servomotor
- 2 Lever, push to engage, push to release
- 3 Adjustable profile cam
- 4 Cam profile adjustment screws
- 5 Opening for access to screws 5
- 6 Index for graduated sector 8
- 7 Graduated sector for gas butterfly valve

(A)

Adjusting air delivery

Progressively adjust the end profile of cam 4)(A) by turning the cam adjustment screws as they appear through the access opening 6)(A).

- Turn the screws clockwise to increase air delivery.
- Turn the screws counter-clockwise to reduce air delivery.

3 - MINIMUM OUTPUT

Minimum output must be selected within the firing rate range shown on page 5.

Press switch 2)(A)p.11 "output reduction" until the servomotor has closed the air damper and the gas butterfly valve to 15° (factory set adjustment).

Adjusting gas delivery

Measure the delivery of gas from the gas meter.

- If this value is to be reduced, decrease the angle of orange cam (B) slightly by proceeding a little at a time until the angle is changed from 15° to 13° or 11°....
- If it has to be increased press the switch "output increase" 2)(A)p.11 (i.e. open the gas butterfly valve by 10-15°), increase the orange cam angle (B) with small successive movements, i.e. take it from angle 15° to 17° - 19°....

Then press the switch "output decrease" until the servomotor is taken to the minimum opening position and measure the gas delivery.

Note

The servomotor follows the adjustment of cam only when the cam angle is reduced. If it is necessary to increase the cam angle, first increase the servomotor angle with the switch "output increase", then increase the orange cam angle, and at the end bring the servomotor back to the MIN output position with the switch "output decrease".

Adjustment of air delivery

Progressively adjust the starting profile of cam 4)(A) by turning the screws working through the access hole 6)(A).

4 - INTERMEDIATE OUTPUTS

Adjustment of gas delivery

No adjustment of gas delivery is required.

Adjustment of air delivery

With the switch 1)(A) page 11 move in intermediate outputs and set the variable profile cam 4) by turning the screws 5).

- If the burner operation is low-high it is sufficient to set only minimum and maximum firing rates
- If the burner operation is modulating, all the points of modulation should be adjusted.

When the adjustment is complete, release the servomotor and manually check there is no binding of the cam.

AIR PRESSURE SWITCH

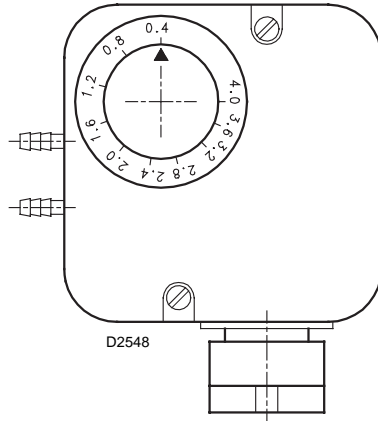

(A)

LOW GAS PRESSURE SWITCH

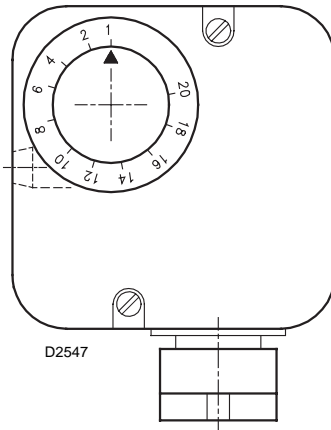

(B)

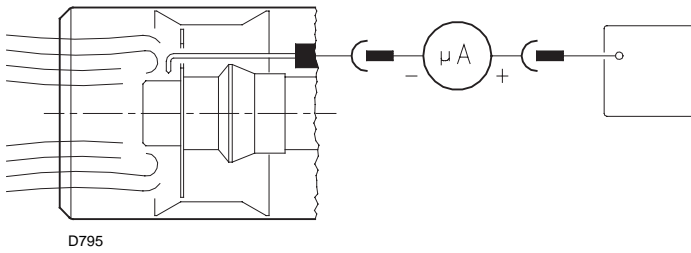

(C)

5 - AIR PRESSURE SWITCH (A) - CO CHECK

Adjust the air pressure switch after having performed all other burner adjustments with the air pressure switch set to the start of the scale (A).
 With the burner operating at min. output, increase adjustment pressure by slowly turning the relative dial clockwise until the burner locks out.
 Then turn the dial anti-clockwise by about 20% of the set point and repeat burner starting to ensure it is correct.
 If the burner locks out again, turn the dial anti-clockwise a little bit more.

Attention:

As a rule, the air pressure switch must prevent the formation of CO.

To check this, insert a combustion analyser into the chimney, slowly close the fan suction inlet (for example with cardboard) and check that the burner locks out, before the CO in the fumes exceeds 400 ppm.

The air pressure switch may operate in "differential" operation in two pipe system. If a negative pressure in the combustion chamber during pre-purging prevents the air pressure switch from switching, switching may be obtained by fitting a second pipe between the air pressure switch and the suction inlet of the fan. In this way the air pressure switch operates as differential pressure switch.

6 - LOW GAS PRESSURE SWITCH (B)

Adjust the low gas pressure switch after having performed all the other burner adjustments with the pressure switch set at the start of the scale (B).
 With the burner operating at MAX output, increase adjustment pressure by slowly turning the relative dial clockwise until the burner locks out.
 Then turn the dial anti-clockwise by 0.8" WC and repeat burner starting to ensure it is uniform.
 If the burner locks out again, turn the dial anti-clockwise again by 0.4" WC.

FLAME PRESENT CHECK (C)

The burner is fitted with an ionisation system (flame rod) which ensures that a flame is present. The minimum current for operation is 6 μA. (or see appropriate documentation of flame safeguard manufacturer)
 The burner provides a much higher current, so that controls are not normally required. However, if it is necessary to measure the ionisation current, disconnect the plug-socket 21)(A)p.4 on the ionisation probe cable and insert a direct current microammeter with a base scale of 100 μA.
 Carefully check polarities!

FLAME INSPECTION WINDOW

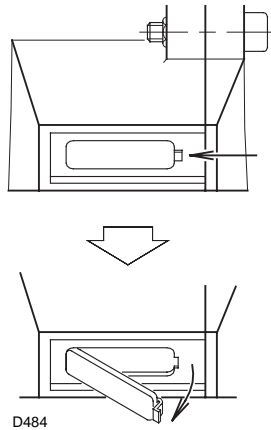

(A)

OPENING THE BURNER

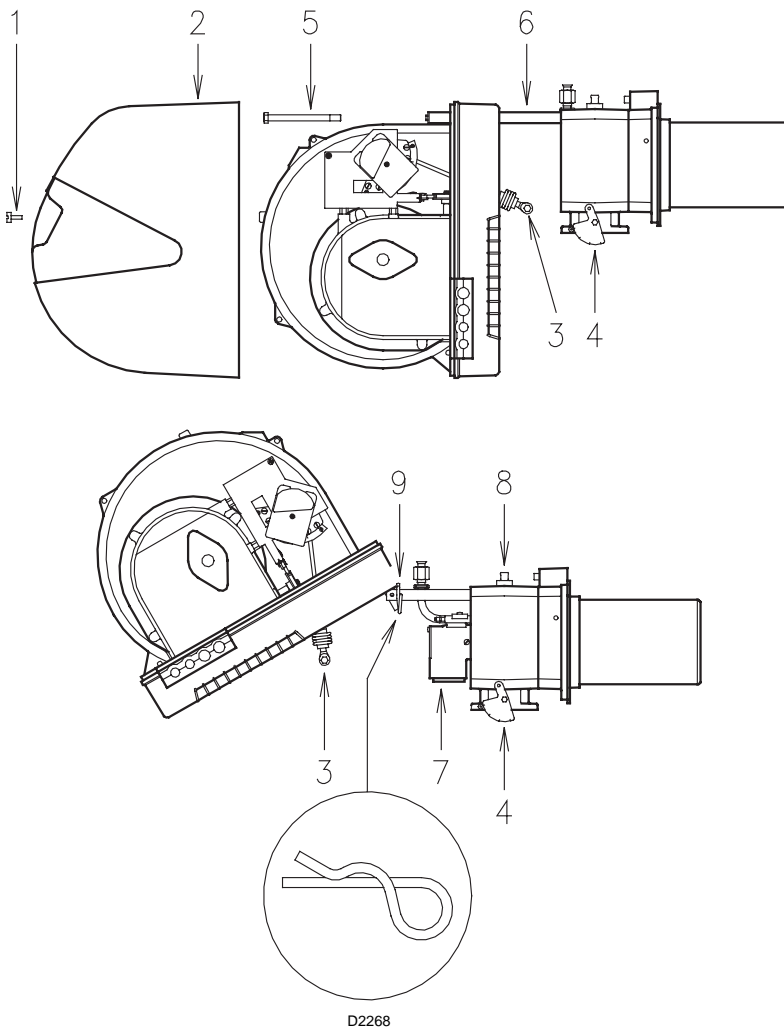

(B)

MAINTENANCE

Combustion

The optimum calibration of the burner requires an analysis of the flue gases. Significant differences with respect to the previous measurements indicate the points where more care should be exercised during maintenance.

Gas leaks

Make sure that there are no gas leaks on the pipework between the gas meter and the burner.

Flame inspection window

Clean the flame inspection window (A).

Combustion head

Open the burner and make sure that all components of the combustion head are in good condition, not deformed by the high temperatures, free of impurities from the surroundings and correctly positioned. If in doubt, disassemble the elbow fitting 7)(B).

Servomotor

Disengage the cam from servomotor and turn it backward and forward by hand to make sure it is free moving. Now engage cam again.

Burner

Check for excess wear or loose screws in the mechanisms controlling the air damper and the gas butterfly valve. Also make sure that the screws securing the electrical leads in the burner connections are fully tightened. Clean the outside of the burner, taking special care with the linkages joints and cam.

Combustion

Adjust the burner if the combustion values found at the beginning of the operation do not comply with the regulations in force, or do not correspond to good combustion.

TO OPEN THE BURNER (B):

- Switch off the electrical power.
- Remove screw 1) and withdraw cover 2).
- Disengage the swivel coupling 3) from the graduated sector 4).
- Remove screw 5), the split pin 9) and pull the burner back by about 4" on the slide bars 6).
- Disconnect the probe and electrode leads and then pull the burner fully back.
- Turn the burner as shown in the figure and fit the split pin 9) into one of the slide bar holes so that the burner remains in position.

Now extract the gas distributor 7) after having removed the screw 8) and disconnecting the pilot gas line.

TO CLOSE THE BURNER (B):

- Remove the split pin 9) and push the burner until it is about 4" from the sleeve.
- Re-connect the leads and slide in the burner until it comes to a stop.
- Refit screw 5), the split pin 9) and pull the probe and electrode leads gently out until they are slightly stretched.
- Re-couple the swivel coupling 3) to the graduated sector 4).
- Connect the pilot gas line.

Factory Wiring Diagram
RS 28/M - RS 38/M single-phase
With Siemens LFL control

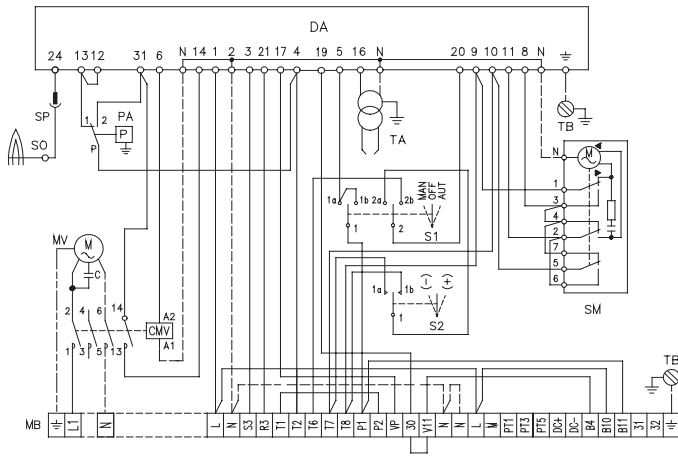

(A)

D2269

Continuous fan operation

Change the wire connection from terminal 6 to terminal 1, move the jumper from terminals 12-13 to terminals 4-12 and remove the wire from terminal 13 of control box as indicated below.

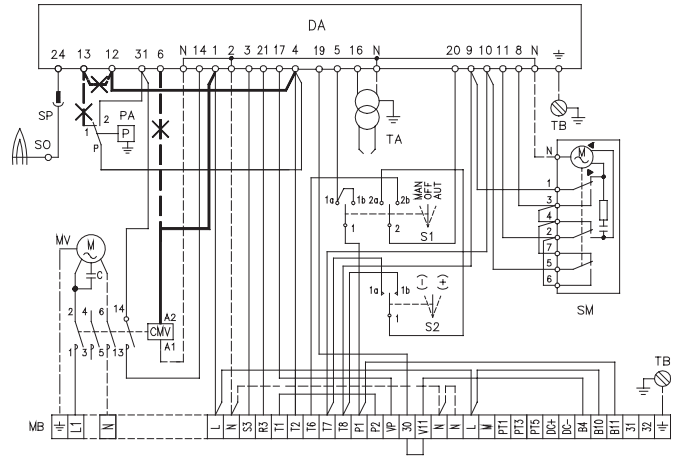

D2876

Factory Wiring Diagram
RS 38/M - RS 50/M three-phase
With Siemens LFL control

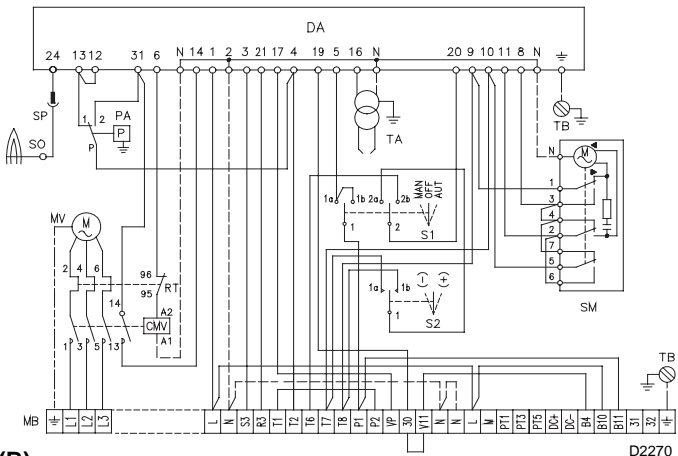

(B)

D2270

Continuous fan operation

Change the wire connection from terminal 6 to terminal 1, move the jumper from terminals 12-13 to terminals 4-12 and remove the wire from terminal 13 of control box as indicated below.

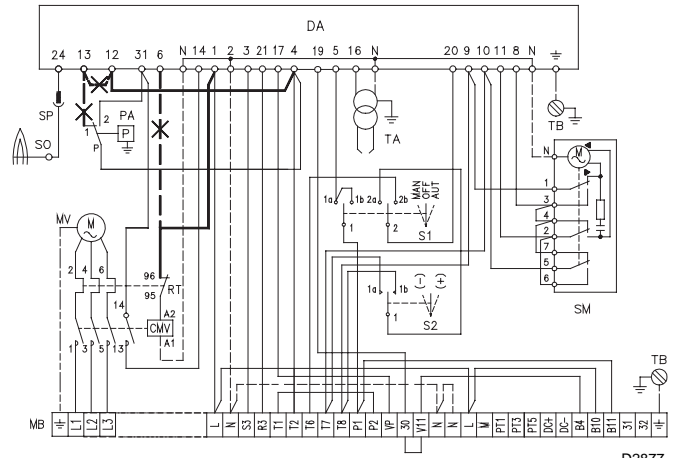

D2877

ELECTRICAL SYSTEM

ELECTRICAL SYSTEM as set up by the manufacturer

LAYOUT (A)

Burner RS 28/M - RS 38/M (single-phase)

LAYOUT (B)

Burners RS 38/M - RS 50/M (three-phase)

- Models RS 38/M and RS 50/M leave the factory preset for **208-230 V** power supply.
- If **460 V** power supply is used, change the motor connection from delta to star and change the setting of the thermal cut-out as well.

Key to Layouts (A) - (B)

- C - Capacitor
- CMV - Motor contactor

- DA - Siemens LFL Control box
- MB - Burner terminal strip
- MV - Fan motor
- PA - Air pressure switch
- RT - Thermal overload
- S1 - Switch for following operations:
 MAN = manual
 AUT = automatic
 OFF
- S2 - Button for:
 - = power reduction
 + = power increase
- SM - Servomotor
- SO - Ionisation probe (flame rod)
- SP - Plug-socket
- TA - Ignition transformer
- TB - Burner ground

**Field Wiring Diagram
RS 28/M - RS 38/M Single-phase
with burner mounted Siemens LFL control**

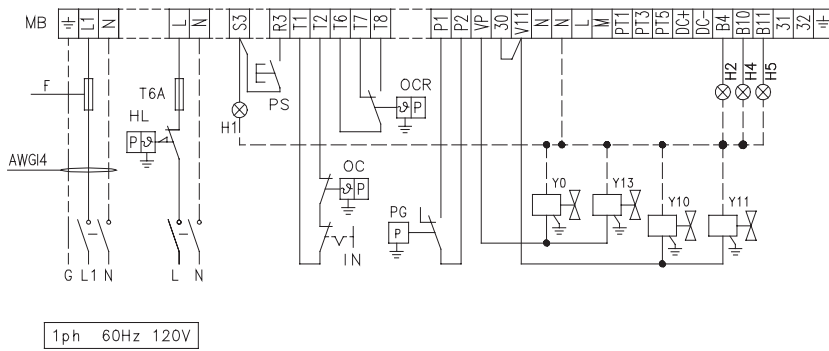

(A) D2271

**Field Wiring Diagram
RS 38/M - RS 50/M Three-phase
With Burner mounted Siemens LFL control**

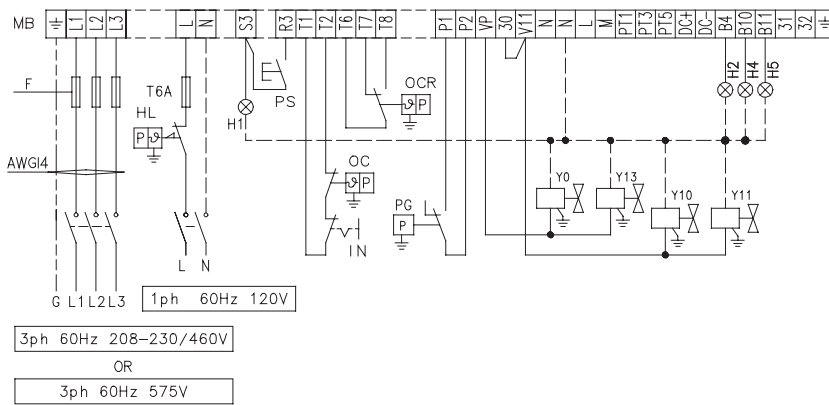

(B) D2272

		RS 28/M	RS 38/M Single-phase	RS 38/M Three-phase			RS 50/M		
		120 V	120 V	208 - 230 V	460 V	460 V	208 - 230 V	460 V	575 V
F	A	T10	T10	T6	T6	T4	T6	T6	T4

(C)
RWF40

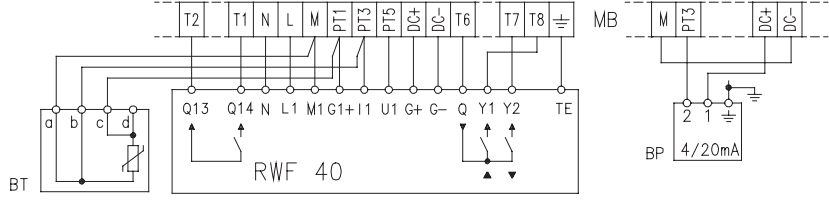

(D) D2322

ELECTRICAL CONNECTIONS

Use flexible cables according to local Regulations.

**LAYOUT (A) - The RS 28/M - RS 38/M models
electrical connection single-phase power supply**

**LAYOUT (B) - The RS 38/M - 50/M models
electrical connection three-phase power supply**

Fuses layout (A) - (B), see table (C).
Wire size when not indicated: AWG18.

KEY TO LAYOUTS (A) - (B)

- IN - Burner manual stop switch
- MB - Burner terminal strip
- PG - Min. gas pressure switch
- PS - Remote lock-out reset
- H1 - Remote lock-out signal
- H2 - Burner on signal
- H4 - Power on signal
- H5 - Permission ok
- OCR - High-low control.
- OC - Operating control.
- HL - High limit.
- Y0 - Pilot valve
- Y10 - Adjustment valve
- Y11 - Safety valve
- Y13 - Pilot valve (safety)

**LAYOUT (D)
Connection of RWF40 and related probe to RS 28-38-50/M burners (modulating operation)**

Note
The OCR and OC controls are not required when the PID control RWF40 is connected, as their function is performed by the RWF40 itself.

It can be connected to the terminals:
- T1 -T2, to replace the remote control TL

Key to layout (D)

- BT - Temperature probe
- BP - Pressure probe
- MB - Burner terminal strip
- a - Red
- b - Red
- c - White
- d - White

NOTES

- The setting of the thermal overload must be according to the total burner amperage draw.
- Models RS 38-50/M leave the factory preset for 208 - 230 V power supply. If 460 V power supply is used, change the motor connection from delta to star and change the setting of the thermal cutout as well.
- Models RS 28-38-50/M have been type- approved for intermittent operation. This means they should compulsorily be stopped at least once every 24 hours to enable the control box to check its own efficiency at start-up. Burner halts are normally provided for automatically by the boiler load control system. If this is not the case, a time switch should be fitted in series to IN to provide for burner shut-down at least once every 24 hours.

Factor Wiring Diagram
RS 28/M - RS 38/M single-phase with Remote Panel

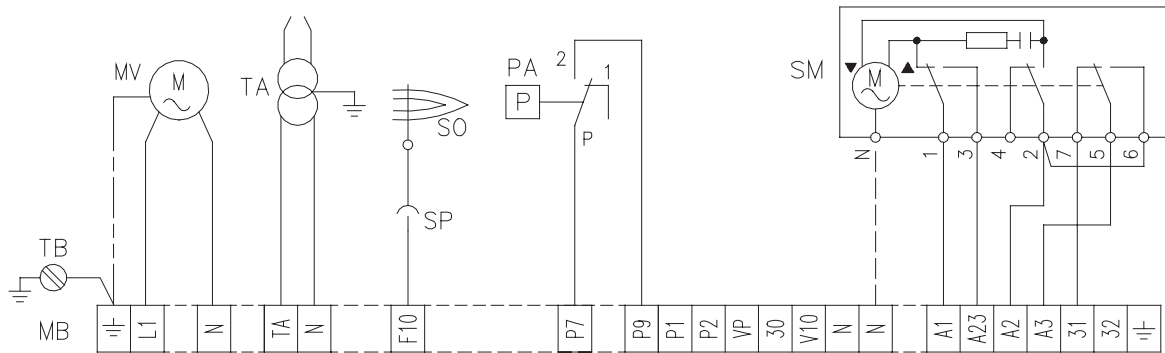

D2396

(A)

Factory Wiring Diagram
RS 38/M - RS 50/M three-phase with remote panel

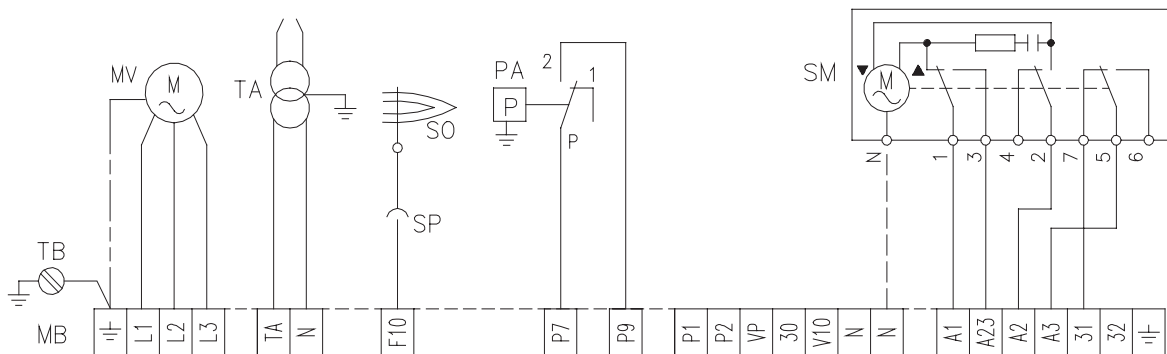

D2403

(B)

ELECTRICAL SYSTEM

ELECTRICAL SYSTEM as set up by the manufacturer

LAYOUT (A)

Burner RS 28/M - RS 38/M (single-phase)

The flame safeguard is in remote panel.

See the internal electrical systems of the remote panel in order to have the complete wiring diagram.

LAYOUT (B)

Burners RS 38/M - RS 50/M (three-phase)

The flame safeguard is in remote panel.

See the internal electrical systems of the remote panel in order to have the complete wiring diagram.

Key to Layouts (A) - (B)

- C - Capacitor
- CMV - Motor contactor
- DA - Siemens LFL Control box
- MB - Burner terminal strip
- MV - Fan motor
- PA - Air pressure switch
- RT - Thermal overload
- S1 - Switch for following operations:
 MAN = manual
 AUT = automatic
 OFF
- S2 - Button for:
 - = power reduction
 + = power increase
- SM - Servomotor
- SO - Ionisation probe (flame rod)
- SP - Plug-socket
- TA - Ignition transformer
- TB - Burner ground

APPENDIX - Burner firing rates according to air density

above sea level		average barom. pressure		CORRECTION FACTOR F								
				Air temperature °F (°C)								
ft	m	" W.C.	mbar	0 (0°C)	41 (5°C)	50 (10°C)	59 (15°C)	68 (20°C)	77 (25°C)	86 (30°C)	104 (40°F)	
0	0	399	1013	1,087	1,068	1,049	1,031	1,013	0,996	0,980	0,948	
329	100	394	1000	1,073	1,054	1,035	1,017	1,000	0,983	0,967	0,936	
658	200	389	989	1,061	1,042	1,024	1,006	0,989	0,972	0,956	0,926	
987	300	385	978	1,050	1,031	1,013	0,995	0,978	0,962	0,946	0,916	
1316	400	380	966	1,037	1,018	1,000	0,983	0,966	0,950	0,934	0,904	
1645	500	376	955	1,025	1,007	0,989	0,972	0,955	0,939	0,923	0,894	
1974	600	372	944	1,013	0,995	0,977	0,960	0,944	0,928	0,913	0,884	
2303	700	367	932	1,000	0,982	0,965	0,948	0,932	0,916	0,901	0,872	
2632	800	363	921	0,988	0,971	0,954	0,937	0,921	0,906	0,891	0,862	
2961	900	358	910	0,977	0,959	0,942	0,926	0,910	0,895	0,880	0,852	
3290	1000	354	898	0,964	0,946	0,930	0,914	0,898	0,883	0,868	0,841	
3947	1200	346	878	0,942	0,925	0,909	0,893	0,878	0,863	0,849	0,822	
4605	1400	337	856	0,919	0,902	0,886	0,871	0,856	0,842	0,828	0,801	
5263	1600	329	836	0,897	0,881	0,866	0,851	0,836	0,822	0,808	0,783	
5921	1800	321	815	0,875	0,859	0,844	0,829	0,815	0,801	0,788	0,763	
6579	2000	313	794	0,852	0,837	0,822	0,808	0,794	0,781	0,768	0,743	

(A)

The FIRING RATE area values have been obtained considering a surrounding temperature of 68°F (20°C), and an atmospheric pressure of 398" W.C. and with the combustion head adjusted as shown on page 8.

The burner may be required to operate with combustion air at a higher temperature and/or at higher altitudes.

Heating of air and increase in altitude produce the same effect: the expansion of the air volume, i.e. the reduction of air density.

The burner fan's delivery remains substantially the same, but the oxygen content per cubic meter and the fan's head are reduced.

It is therefore important to know if the maximum output required of the burner at a given combustion chamber pressure remains within the burner's firing rate range even at different temperature and altitude conditions. Proceed as follows to check the above:

1 - Find the correction factor F in the Table (A) for the plant's air temperature and altitude.

2 - Divide the burner's delivery Q by F in order to obtain the equivalent delivery Q_e:

$$Q_e = Q : F \quad (\text{MBtu/hr})$$

3 - In the firing rate range of the burner, Fig. (B), indicate the work point defined by:

Q_e = equivalent delivery

H₁ = combustion chamber pressure

The resulting point A must remain within the firing rate range.

4 - Plot a vertical line from Point A as shown in Figure (B) and find the maximum pressure H₂ of the firing rate.

5 - Multiply H₂ by F to obtain the maximum reduced pressure H₃ of the firing rate.

$$H_3 = H_2 \times F \quad (\text{" W.C.})$$

If H₃ is greater than H₁, as shown in Fig. (B), the burner delivers the output required.

If H₃ is lower than H₁, the burner's delivery must be reduced. A reduction in delivery is accompanied by a reduction of the pressure in the combustion chamber:

Q_r = reduced delivery

H_{1r} = reduced pressure

$$H_{1r} = H_1 \times \left(\frac{Q_r}{Q}\right)^2$$

Example, a 5% delivery reduction:

$$Q_r = Q \times 0.95$$

$$H_{1r} = H_1 \times (0.95)^2$$

Steps 2 - 5 must now be repeated using the new Q_r and H_{1r} values.

Important: the combustion head must be adjusted in respect to the equivalent delivery Q_e.

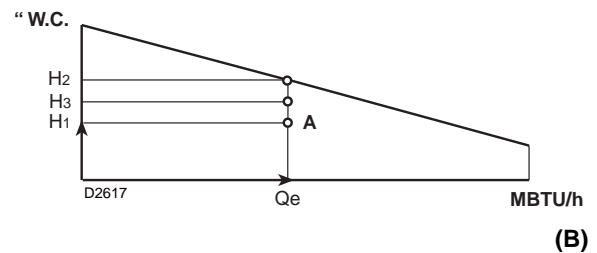

(B)

Full Modulation

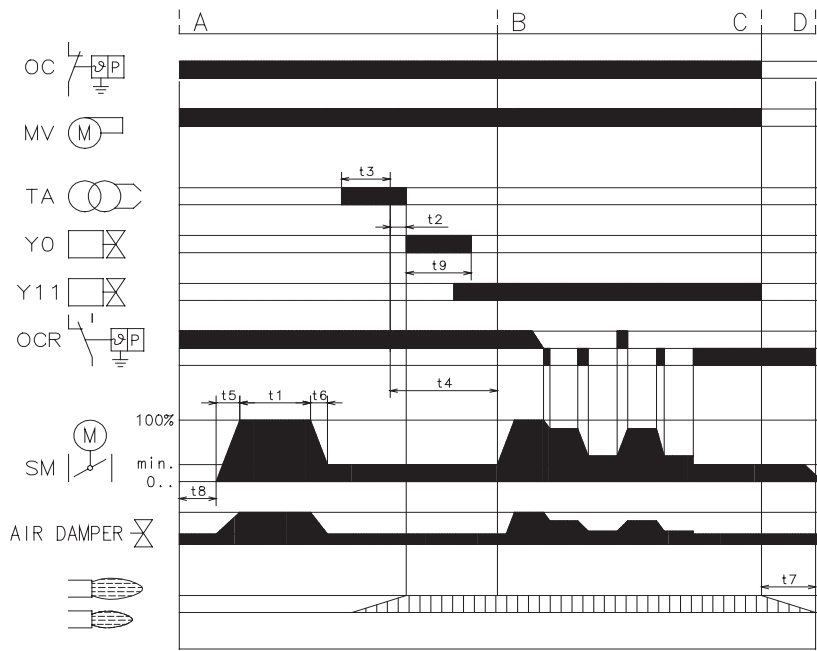

(A)

D2273

Low - High

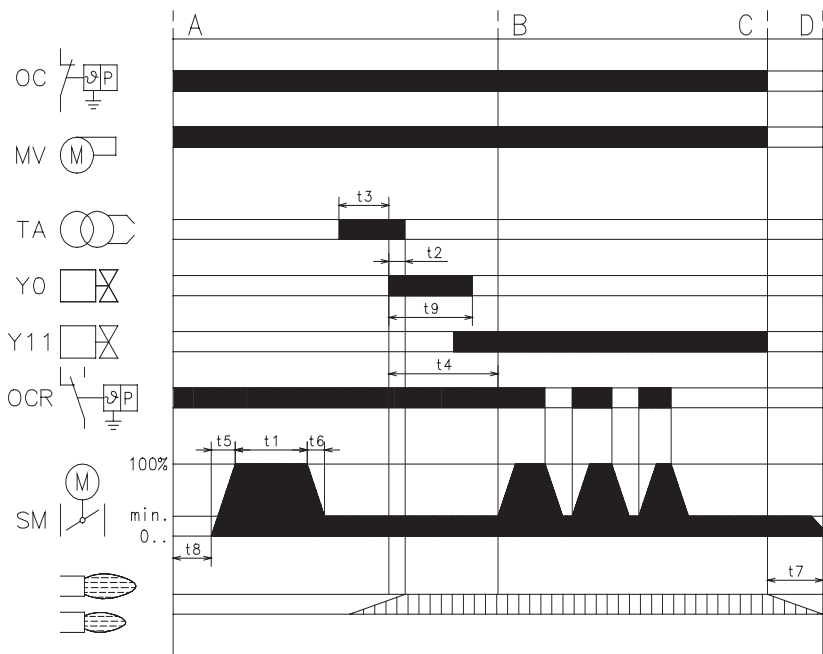

(B)

D2274

BURNER OPERATION

BURNER STARTING

- Operating closes.
- Fan motor starts.
- Servomotor starts:
90° rotation to right, until contact is made on red cam. The air damper is positioned to MAX. output.
- Pre-purge stage with air delivery at MAX. output.
- After pre-purge stage, servomotor rotates to left up to the angle set on blu cam for MIN. output.
- The air damper and the gas butterfly are positioned to MIN. output.
- Ignition electrode strikes a spark.
- Pilot valve opens. The pilot flame is ignited.
- After about 12 s the main flame ignites and starting cycle ends.

STEADY STATE OPERATION

Burner without modulating control RWF40

At the end of the starting cycle, the servomotor control then passes to the load control for boiler pressure or temperature.

(The flame safeguard continues, however, to check that the flame is present and that the air pressure switch is in the correct position.)

- If the temperature or pressure is low, the burner progressively increases its output to the MAX. value.
- If the temperature or pressure is high, the burner progressively decreases its output to the MIN. value. And so on.
- The burner locks out when demand for heat is less than the heat supplied by the burner at min. output. Load control opens. The servomotor returns to the 0° angle limited by contact with orange cam. The air damper closes completely to reduce thermal dispersion to a minimum.

Every time output is changed, the servomotor automatically modifies gas delivery (gas butterfly valve) and air delivery (fan damper).

Burner with modulating control RWF40

See the handbook enclosed with the modulating control.

Switching times are given in seconds, in the burner start-up sequence.

LFL 1.335 Series 01

t1	30	t6	optional
t2	2	t7	12
t3	4	t8	4
t4	20	t9	16
t5	optional		

Legend for the times

- t1 Pre-purge time with air damper open
- t2 Safety time
- t3 Pre-ignition time, short (ignition transformer on terminal 16)
- t4 Interval between start of t2 and release of valve at terminal 19
- t5 Interval between end of t4 and release of load controller or valve at terminal 20
- t5 Running time of air damper into OPEN position
- t6 Running time of air damper into low-flame position (MIN)
- t7 Permissible after-burn time
- t8 Interval until OPEN command for the air damper is given
- t9 Running time of pilot

FIRING FAILURE

If the burner does not fire, it locks out within 2.5 seconds from opening the pilot valve and then within 5 seconds from opening the main valves.

BURNER FLAME GOES OUT DURING OPERATION

If the flame should accidentally go out during operation, the burner will lock out within 1s.

BURNER FAULTS

Control program under fault conditions and lock-out indication

In case of any disturbance, the sequence mechanism stops and with it the lock-out indicator. The symbol above the reading mark of the indicator gives the type of disturbance:

- ◀ **No start**, e.g. because one contact is not closed. Lock-out during or after control program sequence due to extraneous light (e.g. non-extinguished flames, leaking fuel valves, defects in the flame supervision circuit, etc.)

- ▲ **Interruption of startup sequence**, because the OPEN signal has not been delivered to terminal 8 by limit switch "a". Terminals 6, 7 and 14 remain under voltage until the fault has been corrected!

- Ⓟ **Lockout**, because there is no air pressure indication at the beginning of air pressure control. **Every air pressure failure after this moment in time leads to lock-out, too!**

- **Lock-out** due to a fault in the flame supervision circuit.

- ▼ **Interruption of startup sequence**, because the position signal for the low-flame position has not been delivered to terminal 8 by auxiliary switch "m". Terminals 6, 7 and 14 remain under voltage until the fault has been corrected!

- 1 **Lock-out**, because no flame signal is present after completion of the (1st) safety time.

- 2 **Lock-out**, because no flame signal has been received on completion of the 2nd safety time (flame signal of the main flame with interrupted pilot burners).

- | **Lock-out**, because the flame signal has been lost during burner operation.

If lock-out occurs at any other moment in time between the start and the pre-ignition which is not marked by a symbol, this is usually caused by a premature, i.e. faulty flame signal, e.g. caused by a self-igniting UV tube.

BURNER START UP REPORT

Model number: _____	Serial number: _____
Project name: _____	Start-up date: _____
Installing contractor: _____	Phone number: _____

GAS OPERATION					
Gas Supply Pressure: _____	CO ₂ : Low Fire _____	High Fire _____			
Main Power Supply: _____	O ₂ : Low Fire _____	High Fire _____			
Control Power Supply: _____	CO: Low Fire _____	High Fire _____			
Burner Firing Rate: _____	NO _x : Low Fire _____	High Fire _____			
Manifold Pressure: _____	Net Stack Temp - Low Fire: _____	High Fire: _____			
Pilot Flame Signal: _____	Comb. Efficiency - Low Fire: _____	High Fire: _____			
Low Fire Flame Signal: _____	Overfire Draft: _____				
High Fire Flame Signal: _____					

OIL OPERATION					
Oil supply pressure: _____	CO ₂ : Low Fire _____	High Fire _____			
Oil suction pressure: _____	O ₂ : Low Fire _____	High Fire _____			
Control Power Supply: _____	CO: Low Fire _____	High Fire _____			
Burner Firing Rate: _____	NO _x : Low Fire _____	High Fire _____			
Low Fire Flame Signal: _____	Net Stack Temp - Low Fire: _____	High Fire: _____			
High Fire Flame Signal: _____	Comb. Efficiency - Low Fire: _____	High Fire: _____			
Low Fire Nozzle Size: _____	Overfire Draft: _____				
High Fire Nozzle Size: _____	Smoke number: _____				

CONTROL SETTINGS					
Operating Setpoint: _____	Low Oil Pressure: _____	_____			
High Limit Setpoint: _____	High Oil Pressure: _____	_____			
Low Gas Pressure: _____	Flame Safeguard Model Number: _____	_____			
High Gas Pressure: _____	Modulating Signal Type: _____	_____			

NOTES	<hr/> <hr/> <hr/> <hr/>
--------------	-------------------------



Reliable Combustion Solutions

35 Pond Park Road
Hingham, Massachusetts,
U.S.A. 02043

1-800-4-RIELLO
1-800-474-3556
www.riello-burners.com

2165 Meadowpine Blvd.
Mississauga, Ontario,
Canada L5N 6H6