

Dual Fuel Gas / Light Oil Burners



RLS 28 - 38 - 50
Low - High Operation

CONTENTS

FUEL OIL / GAS

Technical data	page 3
Burner models	3
Accessories	3
Burner description	4
Packaging - Weight.	4
Max. dimensions.	4
Standard equipment.	4
Firing rates	5
Minimum furnace dimensions.	5
Installation	6
Boiler plate	6
Blast tube length	6
Securing the burner to the boiler	6

FUEL OIL

Choice of nozzles for 1st and 2nd stage	6
Nozzle assembly	7
Adjustments before first firing.	7

FUEL OIL / GAS

Servomotor.	8
---------------------	---

FUEL OIL

Pump	8
Fuel supply	9
Hydraulic connections	9
Pump priming	9
Burner calibration	10

GAS

Gas pressure	11
Gas piping	12
Adjustments before first firing.	13
Burner starting	13
Burner firing	13
Burner calibration.	14

FUEL OIL / GAS

Maintenance.	16
Hydraulic system layout	17

ELECTRICAL

Factory wiring diagram - RLS 28-38 with burner mounted LFL	18
Factory wiring diagram - RLS 50 with burner mounted LFL.	19
Field wiring diagram - RLS 28-38-50 with burner mounted LFL	20
Factory wiring diagram - RLS 28-38-50 with remote panel	21
Appendix - Burner firing rates according to air density.	22
Flame signal measurement	23
Siemens LFL control sequence of operations	23
Siemens LFL control troubleshooting guide	24
Burner start up report.	25

WARNING

If you smell gas:

- Do not touch any electrical items.
- Open all windows.
- Close all gas supply valves.
- Contact your local gas authority immediately.

Do not store flammable or hazardous materials in the vicinity of fuel burning appliances.

Improper installation, adjustment, alteration, service or maintenance can cause property damage, personal injury or death. Refer to this manual for instructional or additional information. Consult a certified installer, service representative or the gas supplier for further assistance.

Burner shall be installed in accordance with manufacturers requirements as outlined in this manual, local codes and authorities having jurisdiction.

TECHNICAL DATA

MODEL			RLS 28	RLS 38	RLS 50
Output (1)	2nd stage	MBtu/hr (4)	616 - 1232	882 - 1666	1092 - 2198
Delivery (1)		kW	181 - 361	258 - 488	320 - 644
		GPH	4.4 - 8.8	6.3 - 11.9	7.8 - 15.7
	min. 1st stage	MBtu/hr (4)	378	434	546
		kW	111	127	160
		GPH	2.7	3.1	3.9
Fuel			#2 Fuel oil Natural gas / Propane gas		
Gas pressure at maximum delivery (2), Gas: Natural gas		"WC	4.33	5.11	5.51
Operation			low-high		
Nozzles		number	2		
Ambient temperature		°F	32 - 104 (0 - 40 °C)		
Combustion air temperature		°F max	140 (60 °C)		
Main power supply (+/- 10%)		V/Ph/Hz	120/1/60		208-230/460/575/3/60
Electric motors		rpm	3400		
Fan motor		V	120	120	208 - 230 / 460 / 575
		W - HP	370 - 0.5	370 - 0.5	550 - 0.75
		A	5.2	5.2	3.2 - 1.6 - 1.3
Fan motor capacitor		µF	45	45	n/a
Pump motor		V	120		
		W - HP	90 - 0.12		
		A	0,8		
Pump motor capacitor		µF	12,5		
Ignition transformer	Oil	V1 - V2	120 V - 2 x 5 kV		
		I1 - I2	3.7 A - 35 mA		
	Gas	V1 - V2	120 V - 1 x 7 kV		
		I1 - I2	1.6 A - 23 mA		
Pump	Delivery (at 174 PSI)	GPH	21.5		
	Pressure range	PSI	58 - 261		
	Fuel temperature	° F max	140 (60 °C)		
Electrical power consumption		W max	760	760	910
Electrical protection			NEMA 1		
Noise Levels (3)		dBA	68	70	72

(1) Reference conditions: Ambient temperature 68 °F (20°C) - Barometric pressure 394" WC - Altitude 329 ft.

(2) Pressure at test point 7)(A)p.4 with zero pressure in the combustion chamber and maximum burner output.

(3) Sound pressure measured in manufacturer's combustion laboratory, with burner operating on test boiler and at maximum rated output.

(4) Equivalent Btu values based on 1 USGPH = 140,000 Btu/hr.

Burner models designation:

Model	Code	Voltage	Flame safeguard
RLS 28	C9531000 (3483270)	120/1/60	Burner mounted
	C9631000 (3483272)	120/1/60	Remote panel
RLS 38	C9532000 (3484170)	120/1/60	Burner mounted
	C9632000 (3484172)	120/1/60	Remote panel
RLS 50	C9533000 (3484670)	208-230/460/3/60	Burner mounted
	C9533001 (3484670)	575/3/60	Burner mounted
	C9633000 (3484672)	208-230/460/3/60	Remote panel
	C9633001 (3484672)	575/3/60	Remote panel

Accessories (optional):

• Kit for lengthening the combustion head

L = Standard length

L1 = Length obtainable with the kit

COD. 3010264 L = 7 1/2" L1 = 12 27/32" • RLS 28

COD. 3010265 L = 7 29/32" L1 = 13 7/32" • RLS 38

COD. 3010266 L = 8 1/2" L1 = 13 13/16" • RLS 50

• Kit for LPG operation - Code 3010304: The kit allows the RLS 28-38-50 burners to operate on LPG.

• Gas train according to UL Standards: see page 12.

Important:

The installer is responsible for the supply and installation of any required safety device(s) not indicated in this manual.

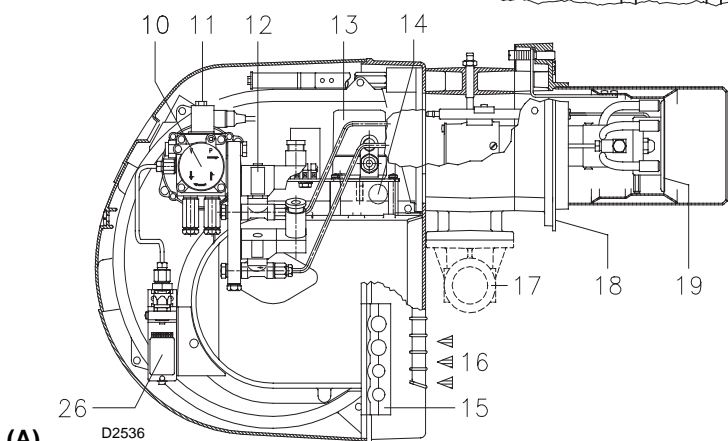
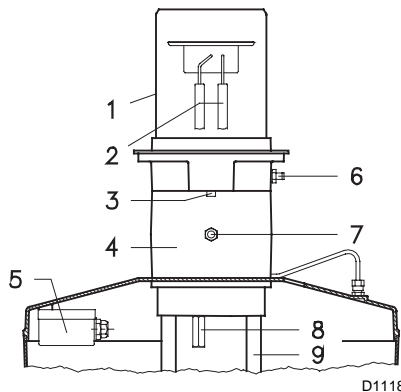
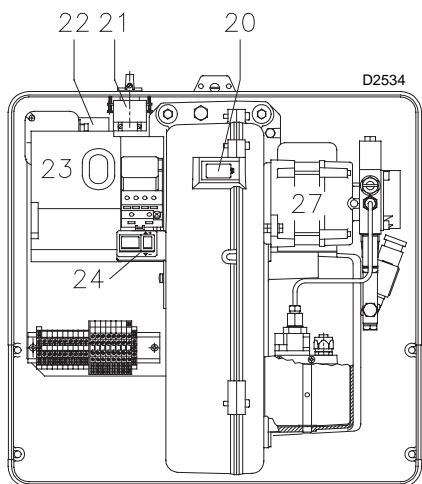

(A)

BURNER DESCRIPTION (A)

- 1 Combustion head
- 2 Ignition electrodes
- 3 Screw for combustion head adjustment
- 4 Sleeve
- 5 Low air pressure switch (differential operating type)
- 6 Air pressure test point
- 7 Gas pressure test point and head fixing screw
- 8 Screw securing fan to sleeve
- 9 Slide bars for opening the burner and inspecting the combustion head
- 10 Pump
- 11 Safety solenoid valve
- 12 Low and high fire oil valves
- 13 Servomotor
- 14 UV scanner
- 15 Plate with four hole knock-outs for flexible hoses and electrical cable routing.
- 16 Air inlet to fan
- 17 Gas input connection
- 18 Boiler mounting flange
- 19 Flame stability disk
- 20 Flame inspection window
- 21 Oil / gas selector switch
- 22 Fan motor contactor and thermal overload with reset button (RLS 50 three-phase)
- 23 Flame safeguard with lock-out pilot light and lock-out reset button
- 24 Power switch for different operations:
automatic - manual - off
Button for:
power increase - power reduction
- 25 Burner terminal strip
- 26 Low oil pressure switch
- 27 Pump motor

Two types of burner failure may occur:

- **Flame safeguard lock-out:**
if the flame relay 23)(A) pushbutton lights up, it indicates that the burner is in lock-out.
To reset, press the pushbutton.
- **Motor trip (RLS 50 three-phase):**
Release by pressing the pushbutton on the thermal overload 22)(A).

inch	A	B	C	lbs
RLS 28	39 ³¹ / ₃₂ "	24 ¹³ / ₁₆ "	19 ¹¹ / ₁₆ "	95
RLS 38	39 ³¹ / ₃₂ "	24 ¹³ / ₁₆ "	19 ¹¹ / ₁₆ "	99
RLS 50	39 ³¹ / ₃₂ "	24 ¹³ / ₁₆ "	19 ¹¹ / ₁₆ "	101

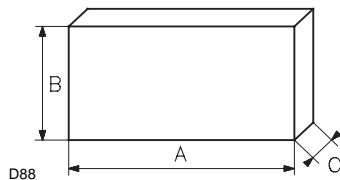

(B)

PACKAGING - WEIGHT (B) - Approximate measurements

- The burners are shipped in cardboard boxes with the maximum dimensions shown in table (B).
- The weight of the burner complete with packaging is indicated in Table (B).

MAX. DIMENSIONS (C) - Approximate measurements

The maximum dimensions of the burners are given in (C).

Note that if you need to examine the combustion head, the burner must be pulled backward on the slide bars and turned upward.

The maximum dimension of the burner, without the cover, when open is given by measurement H.

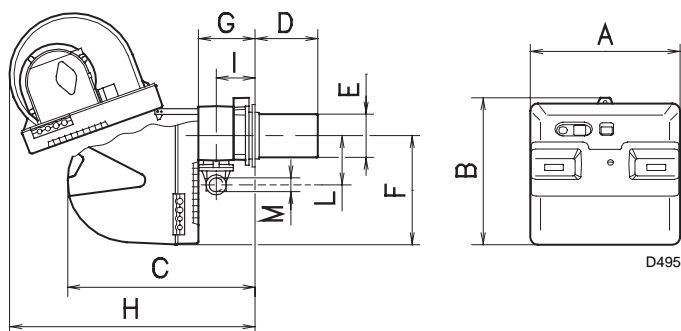

RLS	A	B	C	D	E	F	G	H	I	L	M
28	18 ²³ / ₃₂ "	18 ²¹ / ₃₂ "	22 ¹³ / ₁₆ "	7 ¹ / ₂ "	5 ¹ / ₂ "	13 ²⁷ / ₃₂ "	6 ⁷ / ₁₆ "	31 ⁷ / ₈ "	4 ¹ / ₄ "	6 ⁵ / ₈ "	11 ¹ / ₂ "
38	18 ²³ / ₃₂ "	18 ²¹ / ₃₂ "	22 ¹³ / ₁₆ "	7 ²⁹ / ₃₂ "	5 ³¹ / ₃₂ "	13 ²⁷ / ₃₂ "	6 ⁷ / ₁₆ "	31 ⁷ / ₈ "	4 ¹ / ₄ "	6 ⁵ / ₈ "	11 ¹ / ₂ "
50	18 ²³ / ₃₂ "	18 ²¹ / ₃₂ "	22 ¹³ / ₁₆ "	8 ¹ / ₂ "	5 ³¹ / ₃₂ "	13 ²⁷ / ₃₂ "	6 ⁷ / ₁₆ "	31 ⁷ / ₈ "	4 ¹ / ₄ "	6 ⁵ / ₈ "	11 ¹ / ₂ "

(C)

STANDARD EQUIPMENT

- 1 - Gas train flange
- 1 - Flange gasket
- 4 - Flange fixing screws
- 4 - Screws to secure the burner flange to the boiler:
3/8W x 1"
- 1 - Adaptor G 1/8" / 1/8" NPT
- 1 - Instruction booklet
- 1 - Spare parts list

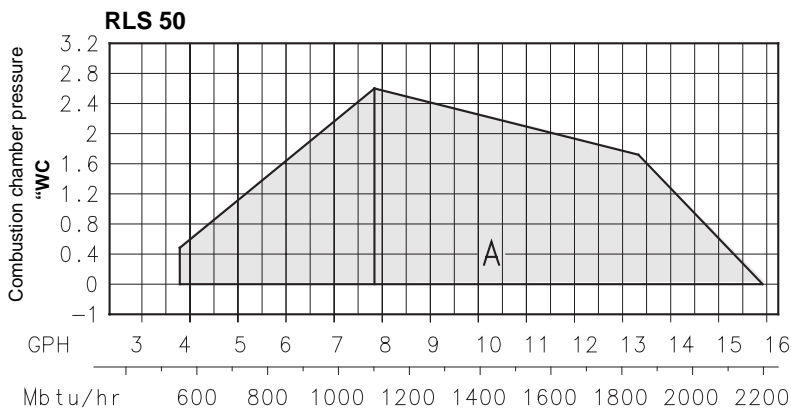
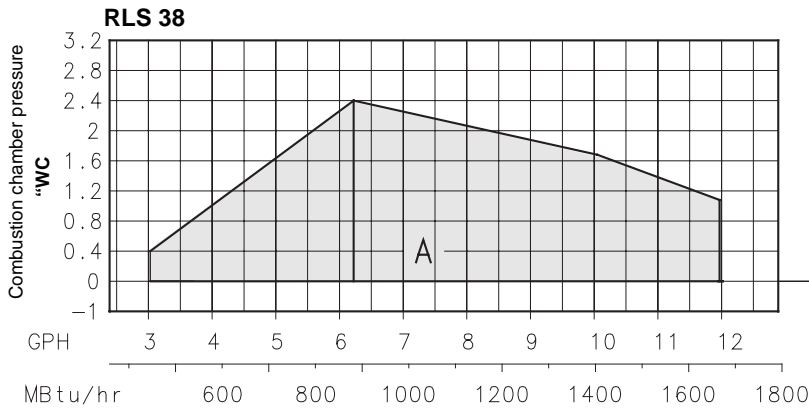
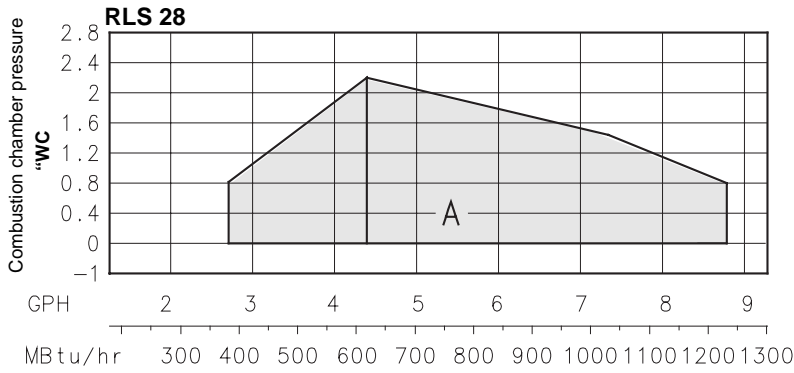

FIRING RATES (A)

The RLS 28 - 38 - 50 Model burners can work in two ways: low and high fire.

MAXIMUM OUTPUT must be selected in area A.

MINIMUM OUTPUT must not be lower than the minimum limit shown in the diagram:

- RLS 28 = 378 MBtu/hr = 2.7 GPH
- RLS 38 = 434 MBtu/hr = 3.1 GPH
- RLS 50 = 546 MBtu/hr = 3.9 GPH

Important:

The firing rate area values have been obtained considering an ambient temperature of 68 °F (20°C), and an atmospheric pressure of 394" WC and with the combustion head adjusted as shown on page 7.

Note:

The FIRING RATE areas given in figure (A) have been reduced by 10% with respect to the maximum range that can be reached.

Consult Appendix on page 22 for operation at different ambient temperatures and/or altitudes.

MINIMUM FURNACE DIMENSIONS (B)

The firing rates were set in relation to certified test boilers.

Figure (B) indicates the diameter and length of the test combustion chamber.

Example:

- output 1388 MBtu/hr:
- diameter 20 inch - length 4.9 ft.

(A)

D2537

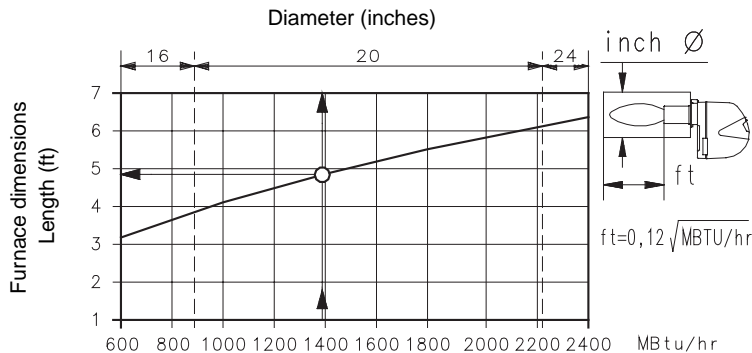

(B)

D2918

inch	A	B	C
RLS 28	6 ⁹ / ₃₂ "	8 ¹³ / ₁₆ "	3 ⁸ / ₈ W
RLS 38	6 ⁹ / ₃₂ "	8 ¹³ / ₁₆ "	3 ⁸ / ₈ W
RLS 50	6 ⁹ / ₃₂ "	8 ¹³ / ₁₆ "	3 ⁸ / ₈ W

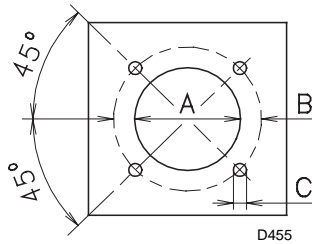

(A)

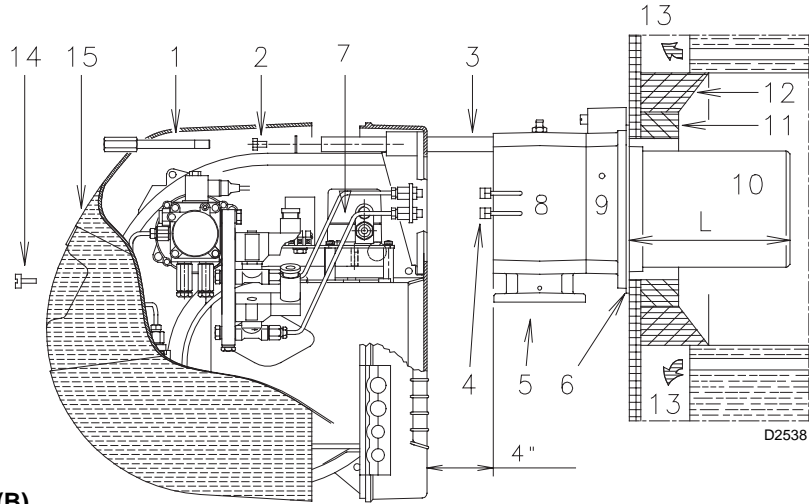

(B)

NOZZLE GPH	GPH			MBTU/h 174 PSI	
	145 PSI	174 PSI	203 PSI		
RLS 28	2.00	2.47	2.72	2.95	381
	2.25	2.75	3.04	3.33	426
	2.50	3.07	3.39	3.68	475
	3.00	3.68	4.07	4.42	570
	3.50	4.32	4.74	5.16	664
RLS 38	2.50	3.07	3.39	3.68	475
	3.00	3.68	4.07	4.42	570
	3.50	4.32	4.74	5.16	664
	4.00	4.93	5.44	5.89	762
	4.50	5.54	6.12	6.63	857
RLS 50	5.00	6.15	6.79	7.36	951
	3.00	3.68	4.07	4.42	570
	3.50	4.32	4.74	5.16	664
	4.00	4.93	5.44	5.89	762
	4.50	5.54	6.12	6.63	857
RLS 50	5.00	6.15	6.79	7.36	951
	5.50	6.76	7.46	8.10	1044
	6.00	7.40	8.17	8.87	1144

(C)

D339

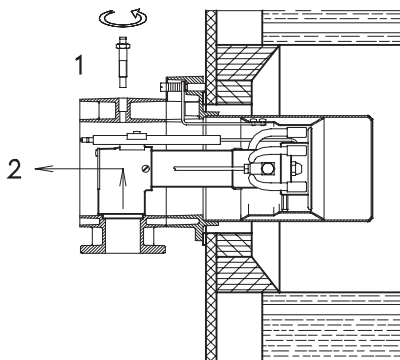

(D)

D1122

INSTALLATION

BOILER PLATE (A)

Drill the combustion chamber mounting plate as shown in (A). The position of the threaded holes can be marked using the head gasket supplied with the burner.

BLAST TUBE LENGTH (B)

The length of the blast tube must be selected according to the indications provided by the manufacturer of the boiler, and it must be greater than the thickness of the boiler door complete with its insulation. The range of lengths available, L (inch), is as follows

Blast tube 10):	RLS 28	RLS 38	RLS 50
• short	7 ¹ / ₂ "	7 ²⁹ / ₃₂ "	8 ¹ / ₂ "
• long	12 ⁷ / ₃₂ "	13 ⁷ / ₃₂ "	13 ¹³ / ₁₆ "

For boilers with front flue passes 13) or flame inversion chambers, protective insulation 11) must be inserted between the boiler refractory 12) and the blast tube 10).

This protective insulation must not compromise the extraction of the blast tube.

For boilers having a water-cooled front the insulation 11)-12)(B) is not required unless it is required by the boiler manufacturer.

SECURING THE BURNER TO THE BOILER (B)

Detach the combustion head from the burner, fig. (B):

- disconnect the oil pipes by unscrewing the two connectors 4).
- remove screw 14) and withdraw the cover 15).
- remove the screws 2) from the slide bars 3).
- remove screw 1) and pull the burner back on slide bars 3) by about 4".

Disconnect the electrode wires and then pull the burner completely off the slide bars, after removing the split pin from the slide bar 3).

Secure the flange 9)(B) to the boiler plate, inserting the gasket 6)(B). Use the 4 screws, also supplied with the unit, after first protecting the thread with an anti-locking product.

The seal between burner and boiler must be airtight.

CHOICE OF NOZZLES FOR 1ST AND 2ND STAGE

Both nozzles must be chosen from among those listed in table (C).

The first nozzle determines the delivery of the burner at low fire.

The second nozzle works together with the 1st nozzle to determine the delivery of the burner at high fire.

The deliveries at low and high fire must be contained within the value range indicated on page 3.

Use nozzles with a 60° spray angle at the recommended pressure of 174 PSI. The two nozzles usually have equal deliveries.

Example with the RLS 28 Model

Boiler output = 921 MBtu/hr @ efficiency 80 %

Output required by the burner =

921 / 0.8 = 1151 MBtu/hr

1151 / 2 = 576 MBtu/hr (4.0 USGPH) per nozzle

therefore, two equal, 60°, 174 PSI nozzles are required:

1° = 4.00 GPH with 2° = 4.00 GPH,

or the following two different nozzles:

1° = 4.50 GPH with 2° = 3.50 GPH,

or:

1° = 3.50 GPH with 2° = 4.50 GPH.

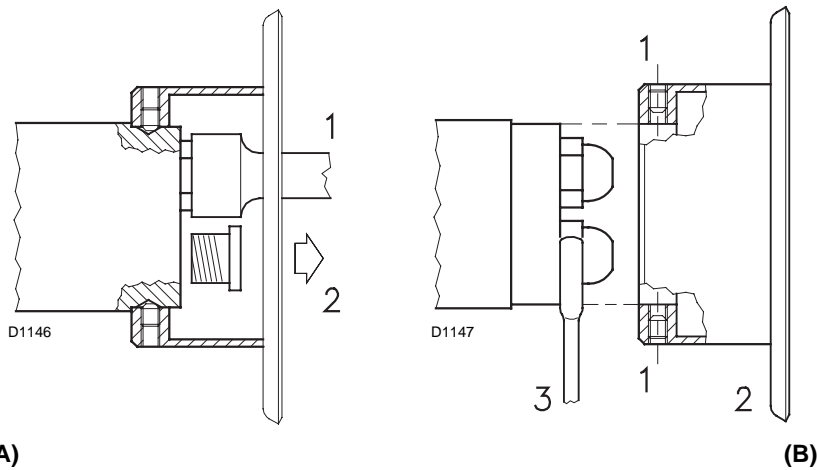

NOZZLE ASSEMBLY

Remove screw 1)(D)p.6 and extract the internal part 2)(D)p.6. Install two nozzles with the box wrench 1)(A), after having removed the plastic plugs 2)(A), fitting the wrench through the central hole in the flame stability disk or loosen screws 1)(B), remove disk 2)(B) and replace the nozzles using the wrench 3)(B).

Do not use any sealing products such as gaskets, sealing compound, or tape. Be careful to avoid damaging the nozzle sealing seat. The nozzles must be screwed into place tightly but carefully.

The nozzle for low fire operation is the one underneath the firing electrodes fig. (C).

Make sure that the electrodes are positioned as shown in figure (C).

Refit the burner 4)(F) to the slide bars 3) at approximately 4" from the sleeve 5) - burner positioned as shown in fig. (B)p. 6 - insert the ignition electrode cables and then slide the burner up to the sleeve so that it is positioned as shown in fig. (F).

Refit screws 2)(F) on slide bars 3).

Secure the burner to the sleeve by tightening screw 1) and then refit the split pin into one of two slide bars 3).

Connect the oil pipes again by screwing on the two connectors 4)(B)p.6.

Important

When fitting the burner on the two slide bars, it is advisable to gently draw out the high tension cables until they are slightly stretched.

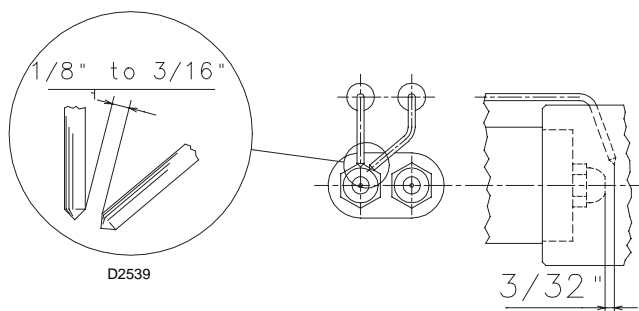

(A)

(B)

(C)

SETTING THE COMBUSTION HEAD

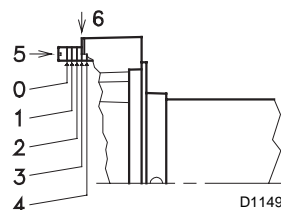

(D)

ADJUSTMENTS BEFORE FIRST FIRING (light-oil operation)

• Combustion head setting

The setting of the combustion head depends exclusively on the delivery of the burner at high fire. Turn screw 5)(D) until the notch shown in diagram (E) is level with the front surface of flange 6)(D).

Example burner RLS 38:

High fire burner delivery = 9.6 GPH.

If diagram (E) is consulted it is clear that for this delivery, the combustion head must be adjusted using notch 4, as shown in fig. (D).

• Pump adjustment

No settings are required for the pump, which is set to 174 PSI by the manufacturer. This pressure must be checked and adjusted (if required) after the burner has been ignited.

The only operation required in this phase is the application of a pressure gauge on the appropriate pump connection.

• Fan damper adjustment

The first time the burner is fired leave the factory setting unchanged for both low and high fire operation.

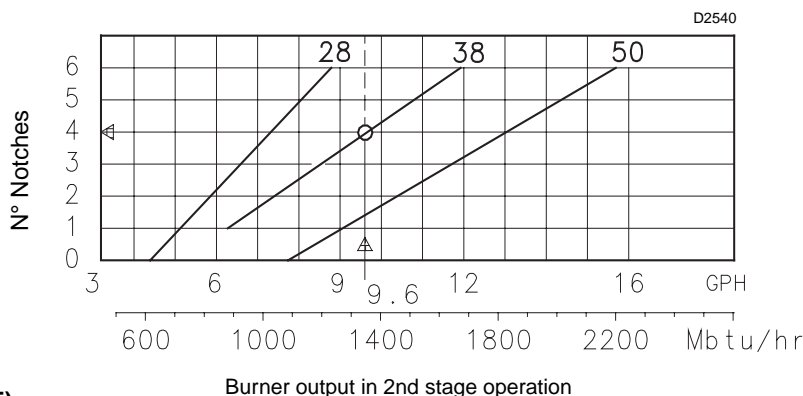

(E)

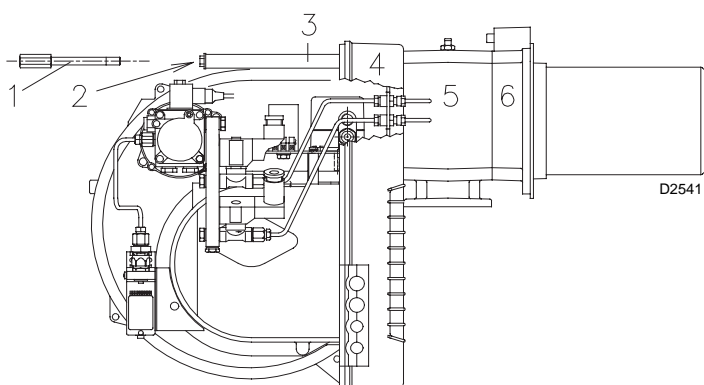

(F)

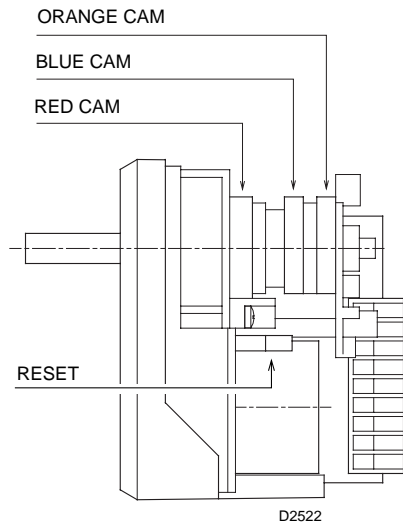

SERVOMOTOR (A)

The servomotor adjusts the air damper. The servomotor rotates through 90° in 25 seconds. Do not alter (for the time-being) the factory setting.

Blue cam

Sets the position of the air damper during low fire operation.

Red cam

Sets the position of the air damper during high fire operation.

Orange cam

Establishes when the high fire gas or fuel oil valve opens. It must always operate (just) before the red cam and after the blue cam.

PUMP (B)

- 1 - Suction 1/4" NPT
- 2 - Return 1/4" NPT
- 3 - Pressure gauge attachment G 1/8"
- 4 - Vacuum gauge attachment G 1/8"
- 5 - Pressure regulator

- A - Min. delivery rate at 174 PSI pressure
- B - Delivery pressure range
- C - Max. suction pressure
- D - Viscosity range
- E - Max fuel oil temperature
- F - Max. suction and return pressure
- G - Pressure calibration in the factory
- H - Filter mesh width

(A)

PUMP

SUNTEC AL 65

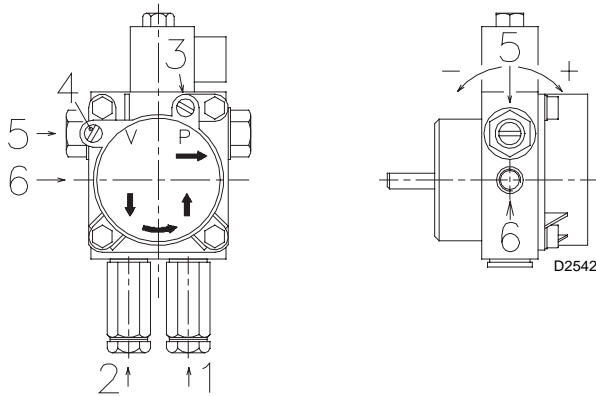

AL 65		
A	GPH	21.5
B	PSI	58 - 261
C	PSI	6.5
D	cSt	2 - 12
E	°F - °C	140 - 60
F	PSI	29
G	PSI	174
H	inch	0.006

(B)

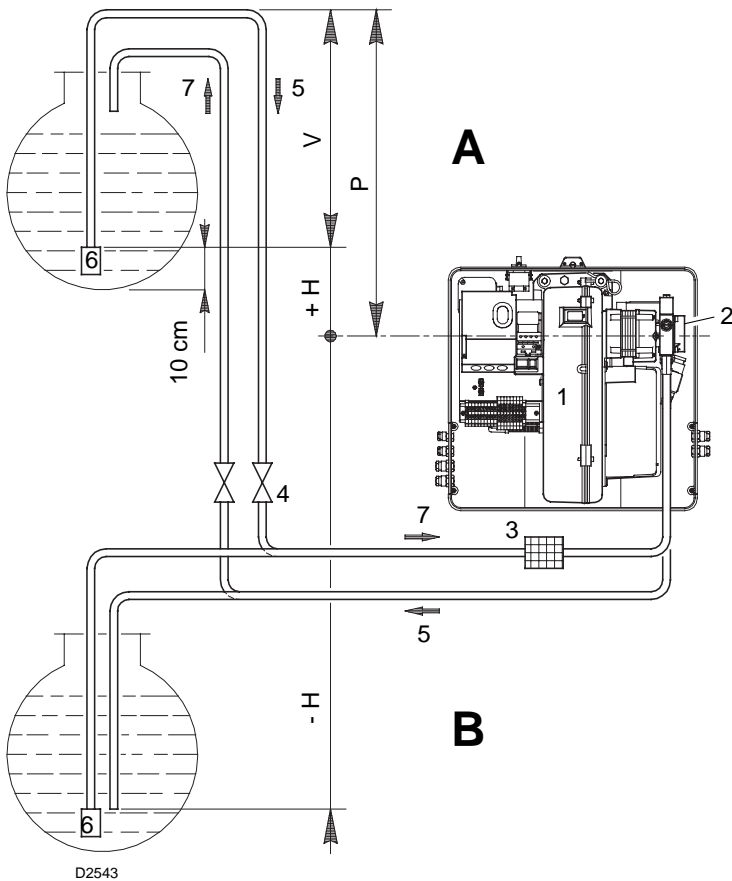

D2543

+ H - H ft	L ft Ø inch		
	5/16"	3/8"	1/2"
+ 13	115	296	500
+ 10	99	263	500
+ 6.6	86	227	500
+ 3.3	69	194	428
+ 1.6	63	174	391
0	56	158	355
- 1.5	49	141	319
- 3.3	43	122	283
- 6.6	30	89	211
- 10	13	53	138
- 13	-	20	66

(A)

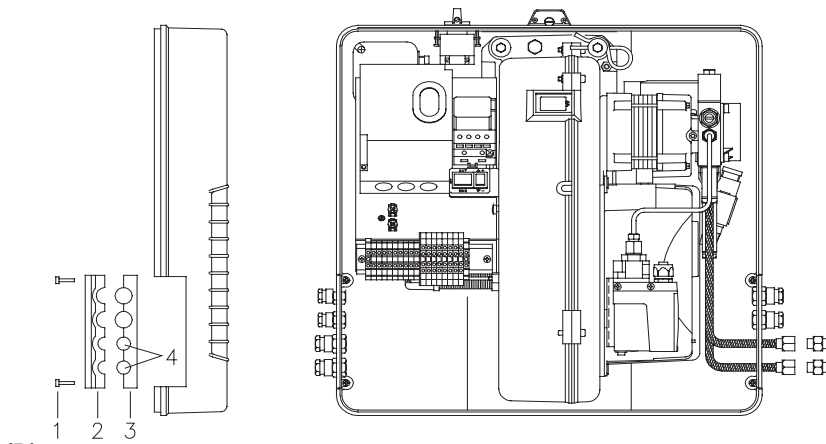

(B)

D2544

FUEL SUPPLY (A)

The burner is equipped with a self-priming pump which is capable of feeding itself within the limits listed in the table at the side.

The tank higher than the burner A

The distance "P" must not exceed 33 ft in order to avoid subjecting the pump's seal to excessive strain; the distance "V" must not exceed 13 ft in order to permit pump self-priming even when the tank is almost completely empty.

The tank lower than the burner B

Pump suction values higher than 6.5 PSI must not be exceeded because at higher levels gas is released from the fuel, the pump starts making noise and its working life-span decreases.

It is good practice to ensure that the return and suction lines enter the burner from the same height; in this way it will be more improbable that the suction line fails to prime or stops priming.

Key

- H = Pump/Foot valve height difference
- L = Piping length
- Ø = Inside pipe diameter
- 1 = Burner
- 2 = Pump
- 3 = Filter
- 4 = Manual on/off valve
- 5 = Suction line
- 6 = Foot valve
- 7 = Return line

HYDRAULIC CONNECTIONS (B)

The pumps are equipped with a by-pass that connects return line and suction line. The pumps are installed on the burner with the by-pass closed by screw 6), see diagram page 17.

It is therefore necessary to connect both hoses to the pump.

The pump seal will be damaged immediately if it is run with the return line closed and the by-pass screw inserted.

Remove the plugs from the suction and return connections of the pump.

Insert the hose connectors into the connections and screw them down.

Take care that the hoses are not stretched or twisted during installation.

Route the hoses through the holes in the plate, preferably using those on the right side, fig.(B): unscrew the screws 1), now divide the insert piece into its two parts 2) and 3) and remove the thin plug blocking the two passages 4). Install the hoses where they cannot be stepped on or come into contact with hot surfaces of the boiler and where they do not hamper the opening of the burner.

Now connect the other end of the hoses to the suction and return lines.

PUMP PRIMING

- Before starting the burner, make sure that the tank return line is not clogged. Obstructions in the line could cause the pump seal located on the pump shaft to break. (The pump leaves the factory with the by-pass closed).
- Also check to make sure that the valves located on the suction line are open and that there is sufficient fuel in the tank.
- For self-priming to take place, one of the screws 3) of the pump, see fig.(B) page 8, must be loosened in order to bleed off the air contained in the suction line

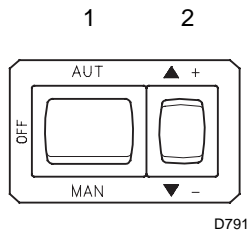

(A)

- Start the burner by closing the control circuit, with switch 1)(A) in the "MAN" position and with switch 21)(A)p.4 in the "OIL" position.
- The pump is primed when the fuel oil starts coming out of the screw 3)(B)p.8. Stop the burner: switch 1)(A) set to "OFF" and tighten the screw 3).

The time required for this operation depends upon the diameter and length of the suction tubing. If the pump fails to prime at the first starting of the burner and the burner locks out, reset the burner, and then repeat the starting operation.

Do not illuminate the UV scanner cell or the burner will lock out.

BURNER CALIBRATION (light-oil operation)

Note

It is advisable to first set the burner for operation on oil and then for gas.

WARNING

Turn burner off prior to switching fuels

• FIRING

Set switch 1)(A) to "MAN".

During the first firing, and the change from low to high fire, there is a momentary lowering of the fuel pressure caused by the filling of the high fire nozzle tubing. This lowering of the fuel pressure can cause the burner to lock-out.

• OPERATION

The optimum calibration of the burner requires an analysis of the flue gases at the boiler outlet and adjustments at the following points:

Low and high fire nozzles

See the information listed on page 6.

Combustion head

The adjustment of the combustion head already carried out (page 7) need not be altered unless the high fire input of the burner is changed.

Pump pressure

174 PSI: this is the pressure calibrated in the factory which is usually sufficient for most purposes. Sometimes, this pressure must be adjusted to:

145 PSI in order to reduce fuel delivery. This adjustment is possible only if the surrounding temperature remains above 0°C;

203 PSI in order to increase fuel delivery or to ensure firings even at temperatures of less than 0°C.

In order to adjust pump pressure, use the screw 5)(B)p.8.

Low fire fan air damper

Keep the burner operating at low fire. The fan air damper is adjusted by moving the blue cam of the servomotor, see page 8.

High fire fan air damper

Press switch 2)(A) "increase output" and keep it pressed until the high fire position. The fan air damper is adjusted by moving the red cam of the servomotor, see page 8.

RLS 28 Δp (" WC)

MBtu/hr	Natural gas
616	2.56
700	2.68
796	2.87
890	3.15
985	3.43
1079	3.78
1174	4.09
1232	4.33

RLS 38 Δp (" WC)

MBtu/hr	Natural gas
882	3.46
985	3.58
1098	3.70
1212	3.86
1325	4.09
1440	4.37
1553	4.65
1666	5.11

RLS 50 Δp (" WC)

MBtu/hr	Natural gas
1092	3.94
1250	4.02
1401	4.13
1553	4.25
1704	4.45
1856	4.61
2007	5.00
2198	5.51

(A)

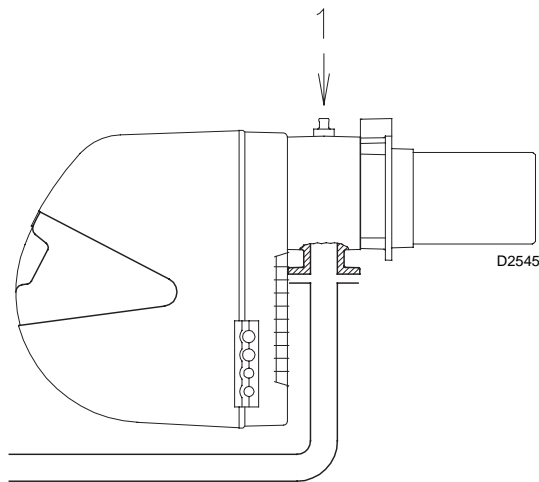

(B)

GAS PRESSURE

The adjacent tables show minimum pressure losses at combustion head depending on the burner output at high fire.

Gas pressure measured at test point 1)(B), with:

- Combustion chamber at 0" WC
- Burner operating at high fire
- Natural gas

Calculate the approximate high fire output of the burner as follows:

- subtract the combustion chamber pressure from the gas pressure measured at test point 1)(B).
- Find the nearest pressure value to your result in the table for the burner in question.
- Read off the corresponding output on the left.

Example - RLS 28

- High fire operation
 - Natural gas
 - Gas pressure at test point 1)(B) = 3.66" WC
 - Pressure in combustion chamber = 0.79" WC
- $$3.66 - 0.79 = 2.87" \text{ WC}$$

A high fire output of 796 MBtu/hr shown in table RLS 28 corresponds to 2.87" WC pressure, natural gas.

This value serves as a rough guide, the effective delivery must be measured at the gas meter.

To calculate the required gas pressure at test point 1)(B), set the output required from the burner in high fire operation:

- find the nearest output value in the table for the burner in question.
- Read off the pressure at test point 1)(B).
- Add this value to the estimated pressure in the combustion chamber.

Example - RLS 28

- Required burner output in high fire operation: 796 MBtu/hr
 - Natural gas
 - Gas pressure at burner output of 796 MBtu/hr, taken from table RLS 28, natural gas = 2.87" WC
 - Pressure in combustion chamber = 0.79" WC
- $$2.87 + 0.79 = 3.66" \text{ WC}$$
- pressure required at test point 1)(B).

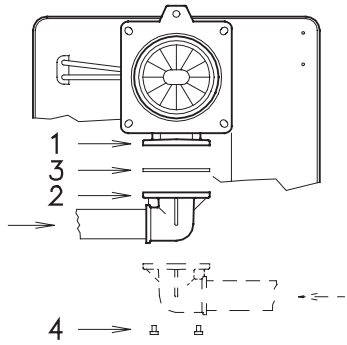

(A)

D1137

TYPICAL SCHEMATIC GAS PIPING

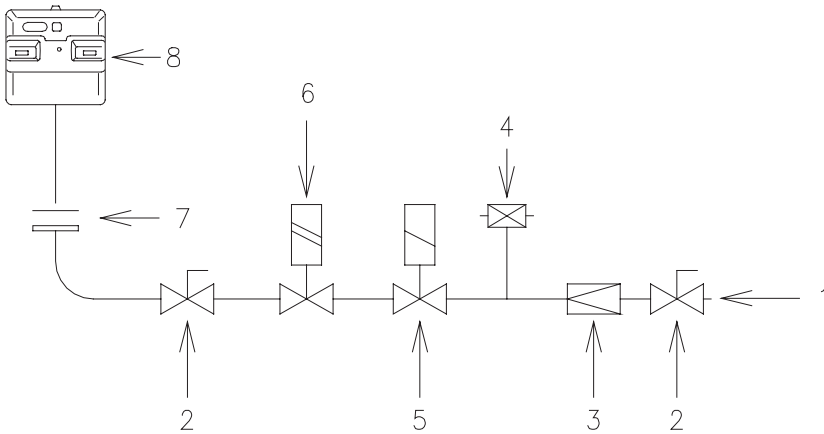

(B)

D2546

GAS PIPING

- The gas train must be connected to the gas attachment 1)(A), using flange 2), gasket 3) and screws 4) supplied with the burner.
- The gas train can enter the burner from the right or left side, depending on which is the most convenient, see fig. (A).
- Gas solenoid 6)(B) must be as close as possible to the burner to ensure gas reaches the combustion head within the safety time period.
- Make sure that the pressure governor calibration range (colour of the spring) comprises the pressure required by the burner.

GAS TRAIN (B)

It must be type-approved according to UL Standards and is supplied separately from the burner.

Note

See the accompanying instructions for the adjustment of the gas train.

KEY TO LAYOUT (B)

- 1 - Gas input pipe
- 2 - Manual valve
- 3 - Pressure regulator
- 4 - Low gas pressure switch
- 5 - Safety solenoid VS
- 6 - 2nd safety shut-off valve
- 7 - Standard issue burner gasket with flange
- 8 - Burner

LOW GAS PRESSURE SWITCH

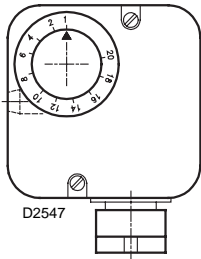

AIR PRESSURE SWITCH

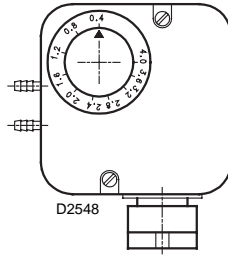

(A)

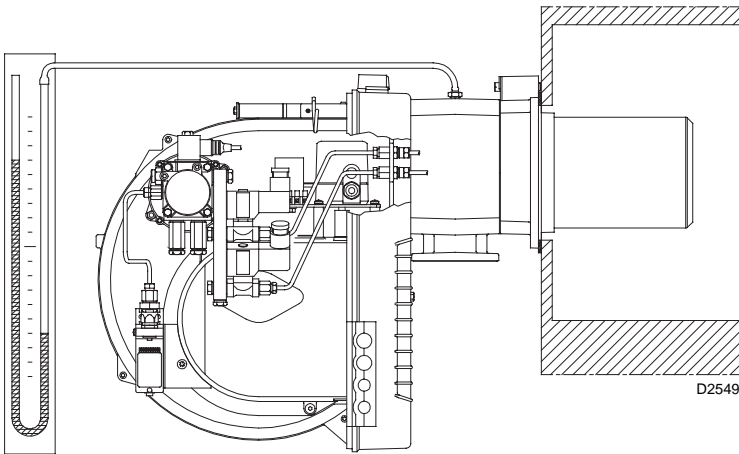

(B)

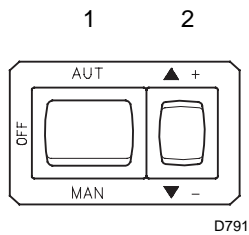

(C)

ADJUSTMENTS BEFORE FIRST FIRING (gas operation)

Adjustment of the combustion head has been illustrated on page 7.

In addition, the following adjustments must also be made:

- open manual valves down stream and up stream from the gas train.
- Adjust the minimum gas pressure switch to the start of the scale (A).
- Adjust the air pressure switch to the zero position of the scale (B).
- Purge the air from the gas line.
- Fit a U-type manometer (C) to the gas pressure test point on the sleeve.

The manometer readings are used to calculate the high fire burner firing rate using the tables on page 11.

Before starting up the burner it is good practice to adjust the gas train so that ignition takes place in conditions of maximum safety, i.e. with gas delivery at the minimum.

BURNER STARTING (gas operation)

NOTE: it is advisable to first set the burner to operate on oil and then on gas.

WARNING
Turn burner off prior to switching fuels

Close the control circuit and set switch 1)(C) to "MAN" position.

BURNER FIRING (gas operation)

Having completed the checks indicated in the previous heading, the burner should fire. If the motor starts but the flame does not appear and the flame relay goes into lock-out, reset and wait for a new firing attempt.

If firing is still not achieved, it may be that gas is not reaching the combustion head within the safety time period.

In this case increase gas firing delivery.

The arrival of gas at the sleeve is indicated by the U-type manometer (C).

Once the burner has fired, proceed with calibration.

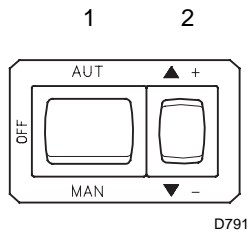

(A)

BURNER CALIBRATION (gas operation)

The optimum calibration of the burner requires an analysis of the flue gases at the boiler outlet.

Adjust successively:

- 1 - High fire burner output
- 2 - Low fire burner output
- 3 - Air pressure switch
- 4 - Minimum gas pressure switch

1 - HIGH FIRE OUTPUT

High fire output of the burner must be set within the firing rate range shown on page 5.

Press switch 2)(A) "output increase": the servomotor will open the air damper at the previously set value for oil and will control the opening of the high fire gas valve.

Gas calibration

Adjust gas delivery to the amount of air at this position.

- If delivery needs to be reduced, diminish outlet gas pressure and, if it is already very low, slightly close high fire adjustment valve.(if installed)
- If delivery needs to be increased, increase outlet gas pressure.

2 - LOW FIRE OUTPUT

Burner power at low fire operation must be selected within the firing rate range shown on page 5.

Press switch 2)(A) "output decrease" and keep it pressed until the low fire position is reached: the servomotor will close the air damper at the previously set value for oil and will control the opening of the low fire gas valve.

Adjusting gas delivery

Adjust gas delivery to the amount of air by adjusting the low fire gas valve VR1.

AIR PRESSURE SWITCH

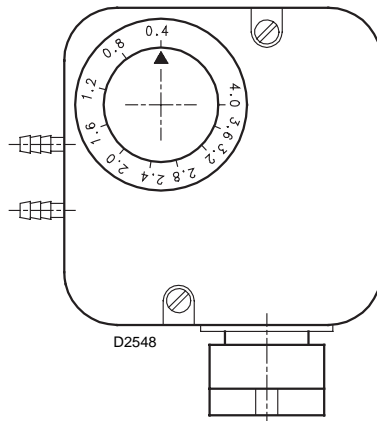

(A)

LOW GAS PRESSURE SWITCH

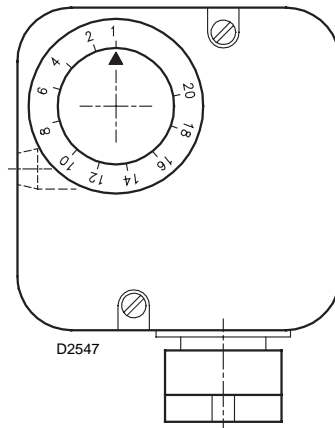

(B)

3 - AIR PRESSURE SWITCH (A) - CO CHECK

Adjust the air pressure switch after having performed all other burner adjustments with the air pressure switch set to the start of the scale (A).

With the burner operating in low fire, increase adjustment pressure by slowly turning the relative dial clockwise until the burner locks out.

Then turn the dial anti-clockwise by about 20% of the set point and repeat burner starting to ensure it is correct.

If the burner locks out again, turn the dial anti-clockwise a little bit more.

Attention:

As a rule, the air pressure switch must block the formation of CO.

To check this, insert a combustion analyser into the chimney, slowly close the fan suction inlet (for example with cardboard) and check that the burner locks out, before the CO in the fumes exceeds 400 ppm.

The air pressure switch may operate in "differential" operation in two pipe system. If a negative pressure in the combustion chamber during pre-purging prevents the air pressure switch from switching, switching may be obtained by fitting a second pipe between the air pressure switch and the suction inlet of the fan. In this way the air pressure switch operates as a differential pressure switch.

4 - LOW GAS PRESSURE SWITCH (B)

Adjust the low gas pressure switch after having performed all the other burner adjustments with the pressure switch set at the start of the scale (B).

With the burner operating at high fire, increase adjustment pressure by slowly turning the relative dial clockwise until the burner locks out.

Then turn the dial anti-clockwise by 0.8" WC and repeat burner starting to ensure it is uniform.

If the burner locks out again, turn the dial anti-clockwise again by 0.4" WC.

FLAME INSPECTION WINDOW

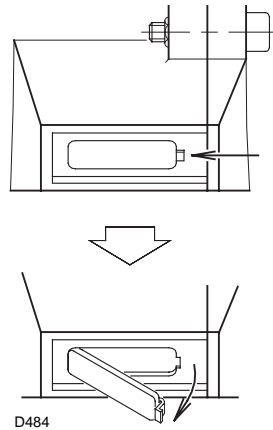

D484

(A)

UV SCANNER

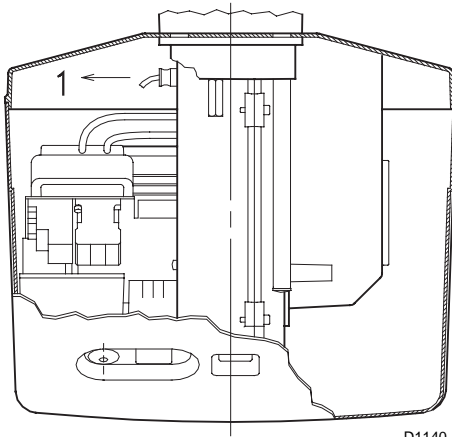

D1140

(B)

OPENING THE BURNER

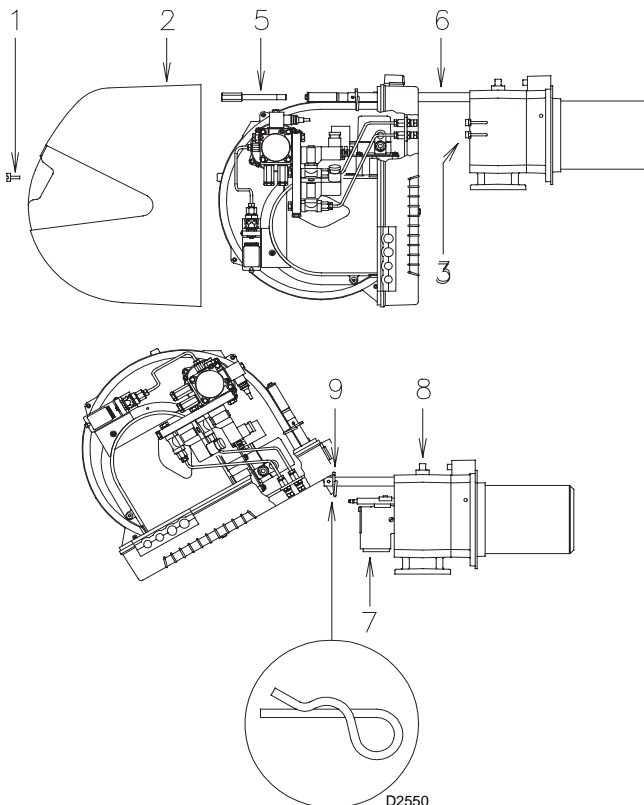

D2550

(C)

MAINTENANCE

Combustion

The optimum calibration of the burner requires an analysis of the flue gases. Significant differences with respect to the previous measurements indicate the points where more care should be exercised during maintenance.

Gas leaks

Make sure that there are no gas leaks on the pipework between the gas meter and the burner.

Flame inspection window

Clean the flame inspection window (A).

Combustion head

Open the burner and make sure that all components of the combustion head are in good condition, not deformed by the high temperatures, free of impurities from the surroundings and correctly positioned. If in doubt, disassemble the elbow fitting 7)(C).

Nozzles (fuel oil)

Do not clean the nozzle orifices.

The nozzle filters however may be cleaned or replaced as required.

Replace the nozzles every 2-3 years or whenever necessary.

Combustion must be checked after the nozzles have been changed.

UV scanner

Clean the glass cover from any dust that may have accumulated. The UV scanner 1)(B) is held in position by a pressure fit and can therefore be removed by pulling it outward.

Flexible hoses (fuel oil)

Check to make sure that the flexible hoses are still in good condition and that they are not crushed or otherwise deformed.

Burner

Check for excess wear or loose screws. Also make sure that the screws securing the electrical leads in the burner connections are fully tightened.

Clean the outside of the burner.

Combustion

Adjust the burner if the combustion values found at the beginning of the operation do not comply with the regulations in force, or do not correspond to good combustion. Record the new combustion values; they will be useful for subsequent comparison.

TO OPEN THE BURNER (C):

- switch off the electrical power.
- Remove screws 1) and withdraw cover 2).
- Disconnect the light-oil pipes 7).
- Remove screw 5), the split pin 9) and pull the burner back by about 4" on the slide bars 6). Disconnect the electrode leads and then pull the burner fully back.
- Tilt the burner as shown in the figure and fit the split pin 9) into one of the slide bar holes so that the burner remains in position

Now extract the internal part 7) after having removed the screw 8).

TO CLOSE THE BURNER (C):

remove the split pin 9) and push the burner until it is about 4" from the sleeve. Re-connect the leads and slide the burner in until it comes to a stop. Refit screw 5), the split pin 9) and pull the leads gently out until they are slightly stretched. Reconnect the light-oil pipes.

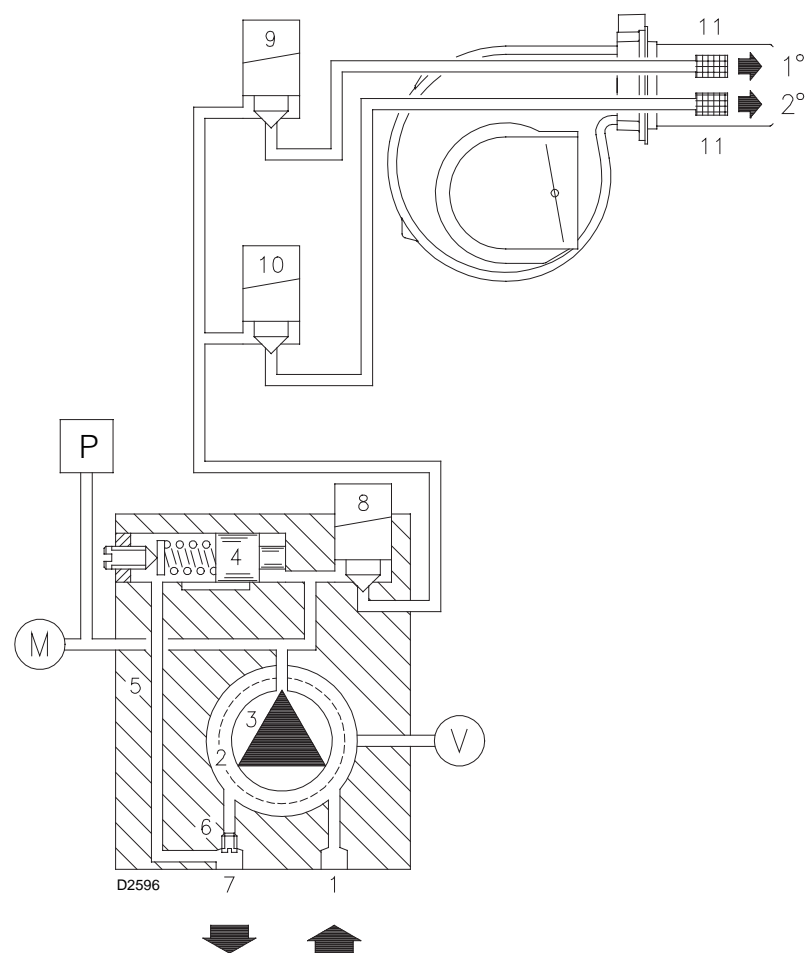

HYDRAULIC SYSTEM LAYOUT (A)

- 1 Pump suction
- 2 Filter
- 3 Pump
- 4 Pressure regulator
- 5 Return pipe
- 6 By-pass screw
- 7 Pump return
- 8 Safety solenoid
- 9 Low fire valve
- 10 High fire valve
- 11 Filter
- M Pressure gauge
- P Low oil pressure switch
- V Vacuum gauge

OIL PRESSURE SWITCH

The oil pressure switch 26)(A) page 4 is factory set to 145 PSI (10 bar). If the oil pressure goes below this value, the pressure switch stops the burner.

COMBUSTION CHECKS

CO₂

It is better to set the burner with CO₂ not higher than 10% (with natural gas). In this way avoiding a loss of calibration setting (for example draft variation) that could cause combustion with little air and the production of CO.

CO

It must be not higher than 400 PPM.

(A)

Factory Wiring Diagram RLS 28 - 38
With burner mounted Siemens LFL control

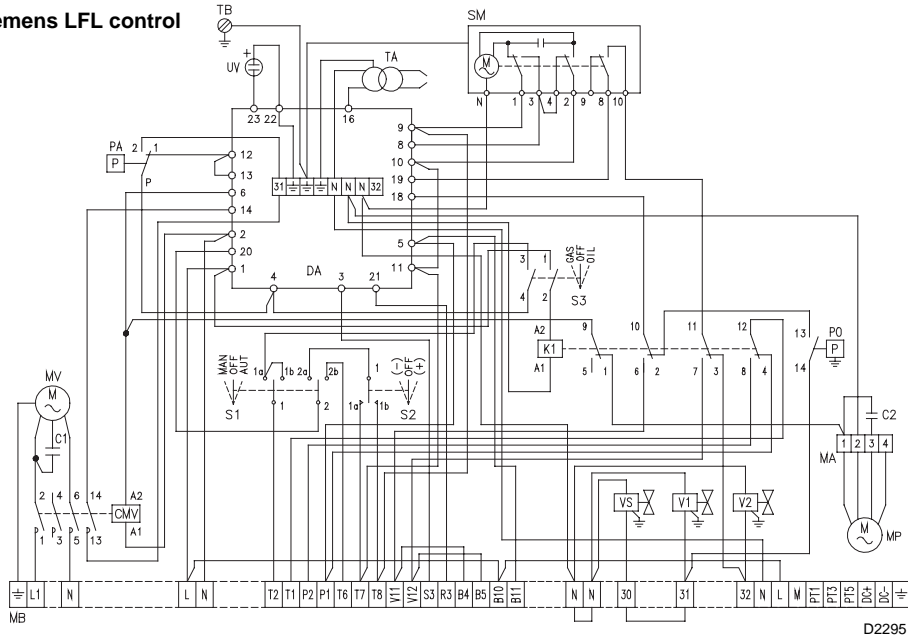

Continuous fan operation

Change the wire connection from terminal 6 to terminal 1, move the jumper from terminals 12-13 to terminals 4-12 and change the K1 - 9 wire connection from terminal A2 of of the motor contactor to terminal 6 of the control box, as indicated below.

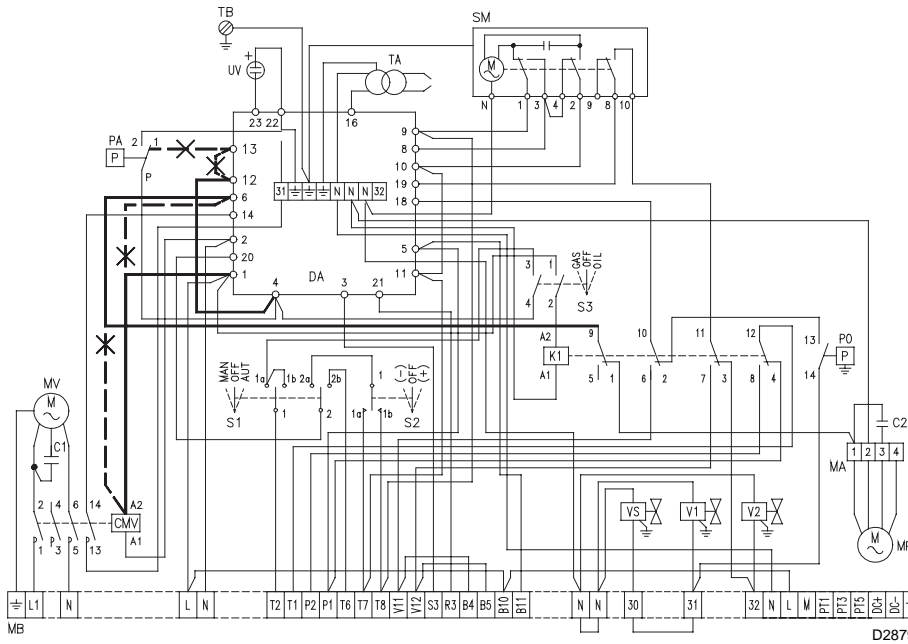

(A)

Burners RLS 28 - 38

Key to layout (A)

- C1 - Fan motor capacitor
- C2 - Pump motor capacitor
- CMV - Motor contactor
- K1 - Relay
- DA - LFL Control box
- S1 - Switch for following operations:
 MAN = manual
 AUT = automatic
 OFF
- S2 - Button for:
 - = power reduction
 + = power increaser

- S3 - OIL/GAS selector
- MA - Auxiliary terminal strip
- MB - Burner terminal strip
- MV - Fan motor
- MP - Pump motor
- PA - Air pressure switch
- PO - Oil pressure switch
- RT - Thermal overload
- SM - Servomotor
- TA - Ignition transformer
- TB - Burner ground
- UV - UV scanner
- V1 - Low fire oil valve
- V2 - High fire oil valve
- VS - Safety oil valve

Factory Wiring Diagram RLS 50
With burner mounted Siemens LFL control

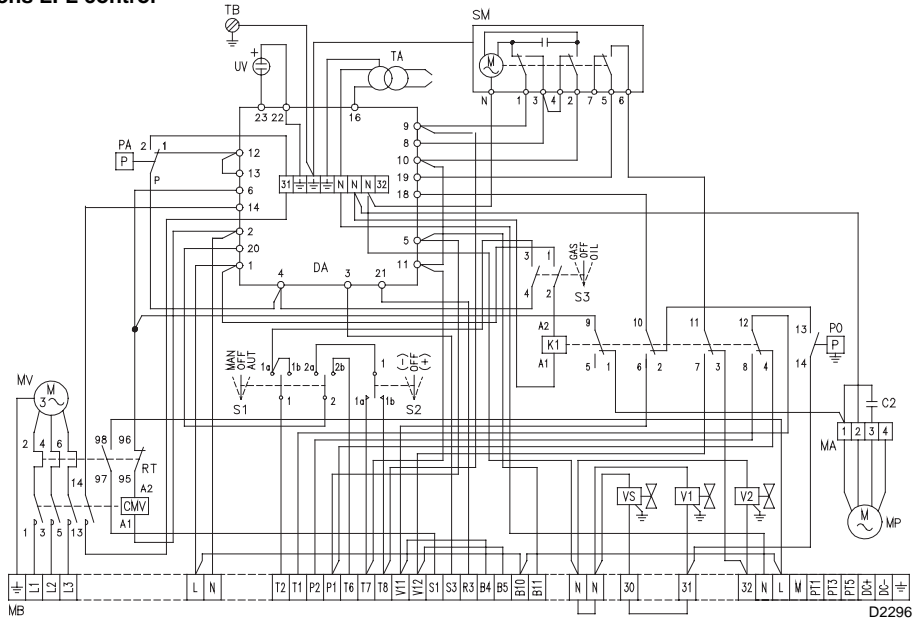

Continuous fan operation

Change the wire connection from terminal 6 to terminal 1, move the jumper from terminals 12-13 to terminals 4-12 and change the K1 - 9 wire connection from terminal A2 of of the motor contactor to terminal 6 of the control box, as indicated below.

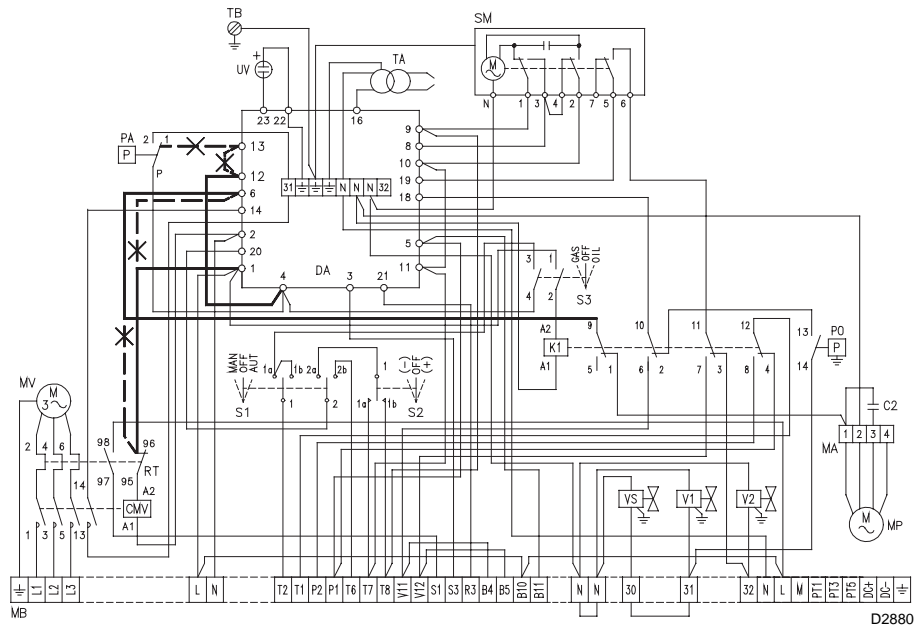

(A)

Burners RLS 50

Key to layout (A)

- C1 - Fan motor capacitor
- C2 - Pump motor capacitor
- CMV - Motor contactor
- K1 - Relay
- DA - LFL Control box
- S1 - Switch for following operations:
 MAN = manual
 AUT = automatic
 OFF
- S2 - Button for:
 - = power reduction
 + = power increaser

- S3 - OIL/GAS selector
- MA - Auxiliary terminal strip
- MB - Burner terminal strip
- MV - Fan motor
- MP - Pump motor
- PA - Air pressure switch
- PO - Oil pressure switch
- RT - Thermal overload
- SM - Servomotor
- TA - Ignition transformer
- TB - Burner ground
- UV - UV scanner
- V1 - Low fire oil valve
- V2 - High fire oil valve
- VS - Safety oil valve

Field Wiring Diagram
RLS 28 - 38 with burner mounted Siemens LFL control

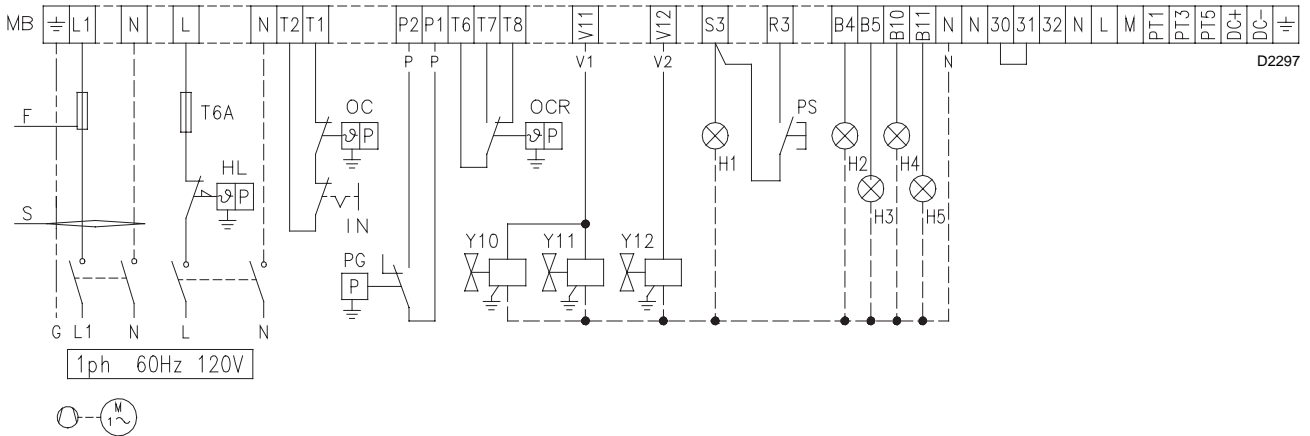

(A)

Field Wiring Diagram
RLS 50 with burner mounted Siemens LFL control

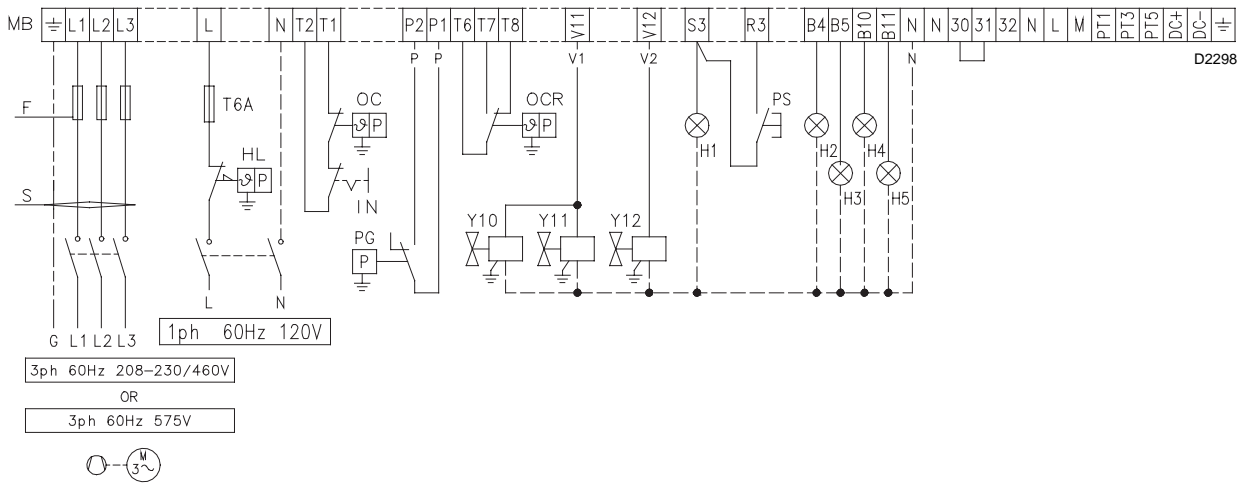

(B)

		RLS 28 - 38		RLS 50	
		120 V		208 - 230 V	460 V 575 V
F	A	T10		T6	T6 T4
S	AWG	14		14	14 14

(C)

ELECTRICAL CONNECTIONS

Use flexible cables according to local Regulations.

LAYOUT (A) - The RLS 28 - RLS 38 Models

LAYOUT (B) - The RLS 50 Model

Fuses and wire size layout (A) -(B), see table (C).
 Wire size when not indicated: AWG18

Key to layouts (A) - (B)

- H1 - Remote lock-out signal
 - H2 - Low fire signal
 - H3 - High signal
 - H4 - Power on signal
 - H5 - Permission ok
 - IN - Burner manual stop switch
 - PG - Low gas pressure switch
 - PS - Remote lock-out reset
 - MB - Burner terminal strip
 - OCR - High-low control.
- If the burner is to be set up for single stage operation install jumper between terminals T6 and T8.

- OC - Operating control.
- HL - High limit
- Y11 - Low fire gas valve
- Y12 - High fire gas valve
- Y10 - Safety gas valve

NOTES

The setting of thermal overload must correspond to the motor amperage on of the burner.

Model RLS 50 three-phase, leaves the factory preset for **460 V** power supply. If **208-230 V** power supply is used, change the fan motor connection from star to delta and change the setting of the thermal overload as well.

The RLS 28-38-50 burners have been type- approved for intermittent operation. This means they should compulsorily be stopped at least once every 24 hours to enable the flame safeguard to check its own efficiency at start-up. Burner halts are normally provided for automatically by the boiler load control system.

If this is not the case, a time switch should be fitted in series to IN to provide for burner shut-down at least once every 24 hours.

**Factory Wiring Diagram
RLS 28 - 38 with remote control panel**

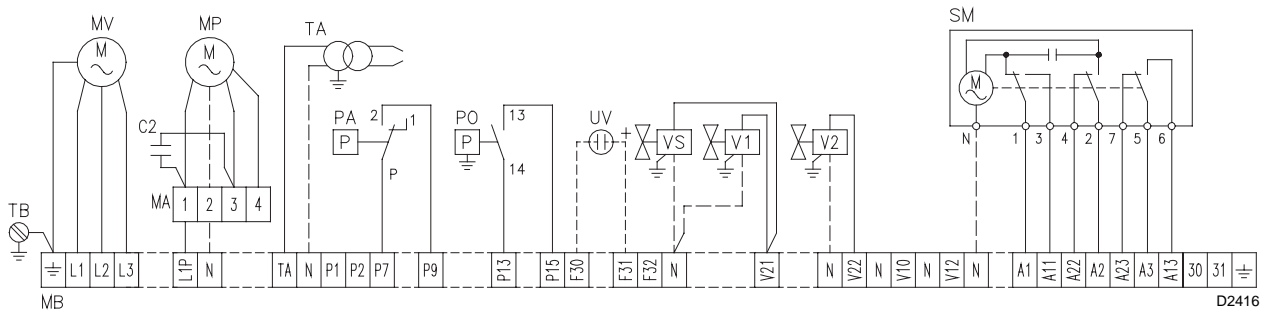

(A)

**Factory Wiring Diagram
RLS 50 with remote control panel**

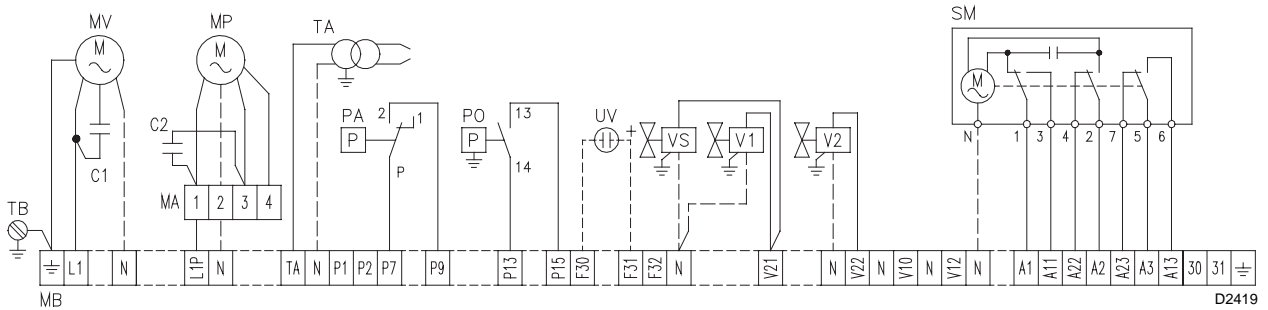

(B)

LAYOUT (A)

Burners RLS 28 - 38

The flame safeguard is in remote panel.

See the internal electrical systems of the remote panel in order to have the complete wiring diagram.

LAYOUT (B)

Burners RLS 50

The flame safeguard is in remote panel.

See the internal electrical systems of the remote panel in order to have the complete wiring diagram.

Key to layout (A) - (B)

- C1 - Fan motor capacitor
- C2 - Pump motor capacitor
- CMV - Motor contactor
- K1 - Relay
- DA - LFL Control box
- S1 - Switch for following operations:
MAN = manual
AUT = automatic
OFF
- S2 - Button for:
- = power reduction
+ = power increaser
- S3 - OIL/GAS selector
- MA - Auxiliary terminal strip

- MB - Burner terminal strip
- MV - Fan motor
- MP - Pump motor
- PA - Air pressure switch
- PO - Oil pressure switch
- RT - Thermal overload
- SM - Servomotor
- TA - Ignition transformer
- TB - Burner ground
- UV - UV scanner
- V1 - Low fire oil valve
- V2 - High fire oil valve
- VS - Safety oil valve

APPENDIX - Burner firing rates according to air density

above sea level		average barom. pressure		CORRECTION FACTOR F								
				Air temperature °F (°C)								
ft	m	" W.C.	mbar	0 (0°C)	41 (5°C)	50 (10°C)	59 (15°C)	68 (20°C)	77 (25°C)	86 (30°C)	104 (40°F)	
0	0	399	1013	1,087	1,068	1,049	1,031	1,013	0,996	0,980	0,948	
329	100	394	1000	1,073	1,054	1,035	1,017	1,000	0,983	0,967	0,936	
658	200	389	989	1,061	1,042	1,024	1,006	0,989	0,972	0,956	0,926	
987	300	385	978	1,050	1,031	1,013	0,995	0,978	0,962	0,946	0,916	
1316	400	380	966	1,037	1,018	1,000	0,983	0,966	0,950	0,934	0,904	
1645	500	376	955	1,025	1,007	0,989	0,972	0,955	0,939	0,923	0,894	
1974	600	372	944	1,013	0,995	0,977	0,960	0,944	0,928	0,913	0,884	
2303	700	367	932	1,000	0,982	0,965	0,948	0,932	0,916	0,901	0,872	
2632	800	363	921	0,988	0,971	0,954	0,937	0,921	0,906	0,891	0,862	
2961	900	358	910	0,977	0,959	0,942	0,926	0,910	0,895	0,880	0,852	
3290	1000	354	898	0,964	0,946	0,930	0,914	0,898	0,883	0,868	0,841	
3947	1200	346	878	0,942	0,925	0,909	0,893	0,878	0,863	0,849	0,822	
4605	1400	337	856	0,919	0,902	0,886	0,871	0,856	0,842	0,828	0,801	
5263	1600	329	836	0,897	0,881	0,866	0,851	0,836	0,822	0,808	0,783	
5921	1800	321	815	0,875	0,859	0,844	0,829	0,815	0,801	0,788	0,763	
6579	2000	313	794	0,852	0,837	0,822	0,808	0,794	0,781	0,768	0,743	

(A)

The FIRING RATE area values have been obtained considering a surrounding temperature of 68°F (20°C), and an atmospheric pressure of 398" W.C. and with the combustion head adjusted as shown on page 7.

The burner may be required to operate with combustion air at a higher temperature and/or at higher altitudes.

Heating of air and increase in altitude produce the same effect: the expansion of the air volume, i.e. the reduction of air density.

The burner fan's delivery remains substantially the same, but the oxygen content per cubic meter and the fan's head are reduced.

It is therefore important to know if the maximum output required of the burner at a given combustion chamber pressure remains within the burner's firing rate range even at different temperature and altitude conditions. Proceed as follows to check the above:

1 - Find the correction factor F in the Table (A) for the plant's air temperature and altitude.

2 - Divide the burner's delivery Q by F in order to obtain the equivalent delivery Q_e:

$$Q_e = Q : F \text{ (MBTU/h)}$$

3 - In the firing rate range of the burner, Fig. (B), indicate the work point defined by:

Q_e = equivalent delivery

H₁ = combustion chamber pressure

The resulting point A must remain within the firing rate range.

4 - Plot a vertical line from Point A as shown in Figure (B) and find the maximum pressure H₂ of the firing rate.

5 - Multiply H₂ by F to obtain the maximum reduced pressure H₃ of the firing rate.

$$H_3 = H_2 \times F \text{ (" W.C.)}$$

If H₃ is greater than H₁, as shown in Fig. (B), the burner delivers the output required.

If H₃ is lower than H₁, the burner's delivery must be reduced. A reduction in delivery is accompanied by a reduction of the pressure in the combustion chamber:

Q_r = reduced delivery

H_{1r} = reduced pressure

$$H_{1r} = H_1 \times \left(\frac{Q_r}{Q} \right)^2$$

Example, a 5% delivery reduction:

$$Q_r = Q \times 0.95$$

$$H_{1r} = H_1 \times (0.95)^2$$

Steps 2 - 5 must now be repeated using the new Q_r and H_{1r} values.

Important: the combustion head must be adjusted in respect to the equivalent delivery Q_e.

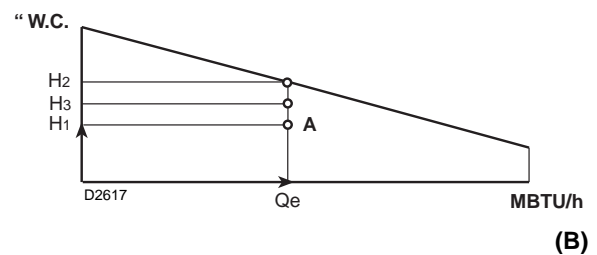

(B)

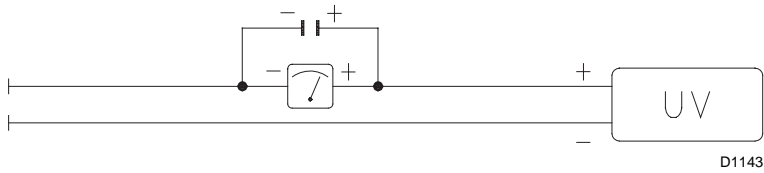

(A)

High - Low

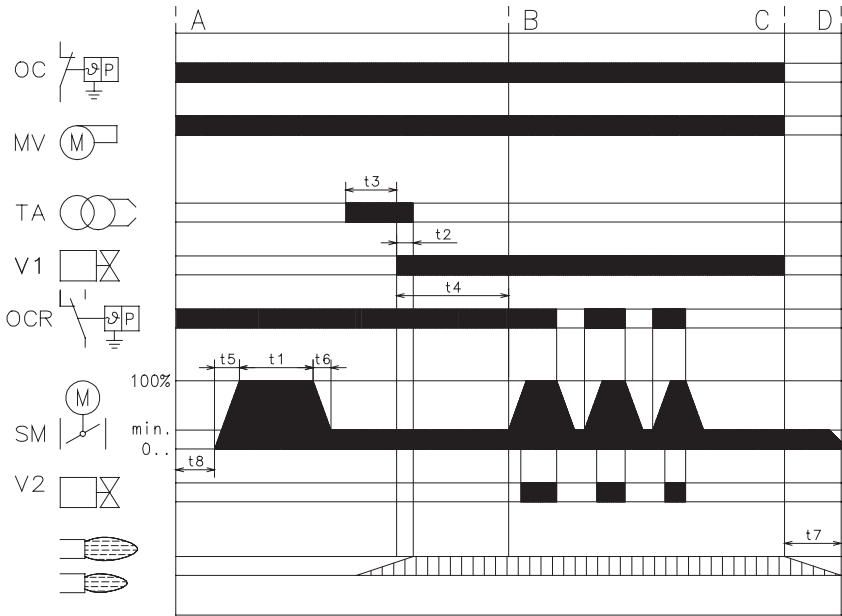

(B)

FLAME SIGNAL

Min value for a good signal: 70 μ A.
If the value is lower, it can be due to:

- Worn scanner;
- Low current;
- Bad set up of the burner.

In order to measure the current, use a microammeter of 100 μ A c.c., connected to the scanner, with a capacitor of 100 μ F - 1V c.c. at the same level of the instrument. See fig. (A).

SEQUENCE OF OPERATION

See fig. (B) - (C).

LFL 1.335 Series 01

t1	30	t6	optional
t2	2	t7	12
t3	4	t8	4
t4	20		
t5	optional		

Legend for the times

- t1** Pre-purge time with air damper open
- t2** Safety time
- t3** Pre-ignition time, short (ignition transformer on terminal 16)
- t4** Interval between start of t2 and release of valve at terminal 19
- t5** Interval between end of t4 and release of load controller or valve at terminal 20
- t6** Running time of air damper into OPEN position
- t7** Running time of air damper into low-flame position (MIN)
- t8** Permissible after-burn time
- t8** Interval until OPEN command for the air damper is given

FIRING FAILURE

If the burner does not fire, it locks out within 2.5 seconds from opening the pilot valve and then within 5 seconds from opening the main valves.

BURNER FLAME GOES OUT DURING OPERATION

If the flame should accidentally go out during operation, the burner will lock out within 1s.

Control program under fault conditions and lock-out indication

In case of any disturbance, the sequence mechanism stops and with it the lock-out indicator. The symbol above the reading mark of the indicator gives the type of disturbance:

- ◀ **No start**, e.g. because one contact is not closed. Lock-out during or after control program sequence due to extraneous light (e.g. non-extinguished flames, leaking fuel valves, defects in the flame supervision circuit, etc.).

- ▲ **Interruption of startup sequence**, because the OPEN signal has not been delivered to terminal 8 by cam 1 (gas) or cam 4 (oil). Terminals 6, 7 and 14 remain under voltage until the fault has been corrected!

- Ⓟ **Lockout**, because there is no air pressure indication at the beginning of air pressure control. **Every air pressure failure after this moment in time leads to lock-out, too!**

- **Lock-out** due to a fault in the flame supervision circuit.

- ▼ **Interruption of startup sequence**, because the position signal for the low-flame position has not been delivered to terminal 8 by cam 3 (gas) or cam 5 (oil). Terminals 6, 7 and 14 remain under voltage until the fault has been corrected!

- 1 **Lock-out**, because no flame signal is present after completion of the (1st) safety time.

- 2 **Lock-out**, because no flame signal has been received on completion of the 2nd safety time (flame signal of the main flame with interrupted pilot burners).

- | **Lock-out**, because the flame signal has been lost during burner operation.

If lock-out occurs at any other moment in time between the start and the pre-ignition which is not marked by a symbol, this is usually caused by a premature, i.e. faulty flame signal, e.g. caused by a self-igniting UV tube.

BURNER START UP REPORT

Model number: _____	Serial number: _____
Project name: _____	Start-up date: _____
Installing contractor: _____	Phone number: _____

GAS OPERATION					
Gas Supply Pressure: _____	CO ₂ : Low Fire _____	High Fire _____	_____	_____	_____
Main Power Supply: _____	O ₂ : Low Fire _____	High Fire _____	_____	_____	_____
Control Power Supply: _____	CO: Low Fire _____	High Fire _____	_____	_____	_____
Burner Firing Rate: _____	NO _x : Low Fire _____	High Fire _____	_____	_____	_____
Manifold Pressure: _____	Net Stack Temp - Low Fire: _____	High Fire: _____	_____	_____	_____
Pilot Flame Signal: _____	Comb. Efficiency - Low Fire: _____	High Fire: _____	_____	_____	_____
Low Fire Flame Signal: _____	Overfire Draft: _____	_____	_____	_____	_____
High Fire Flame Signal: _____	_____	_____	_____	_____	_____

OIL OPERATION					
Oil supply pressure: _____	CO ₂ : Low Fire _____	High Fire _____	_____	_____	_____
Oil suction pressure: _____	O ₂ : Low Fire _____	High Fire _____	_____	_____	_____
Control Power Supply: _____	CO: Low Fire _____	High Fire _____	_____	_____	_____
Burner Firing Rate: _____	NO _x : Low Fire _____	High Fire _____	_____	_____	_____
Low Fire Flame Signal: _____	Net Stack Temp - Low Fire: _____	High Fire: _____	_____	_____	_____
High Fire Flame Signal: _____	Comb. Efficiency - Low Fire: _____	High Fire: _____	_____	_____	_____
Low Fire Nozzle Size: _____	Overfire Draft: _____	_____	_____	_____	_____
High Fire Nozzle Size: _____	Smoke number: _____	_____	_____	_____	_____

CONTROL SETTINGS					
Operating Setpoint: _____	Low Oil Pressure: _____	_____	_____	_____	_____
High Limit Setpoint: _____	High Oil Pressure: _____	_____	_____	_____	_____
Low Gas Pressure: _____	Flame Safeguard Model Number: _____	_____	_____	_____	_____
High Gas Pressure: _____	Modulating Signal Type: _____	_____	_____	_____	_____

NOTES					



Reliable Combustion Solutions

35 Pond Park Road
Hingham, Massachusetts,
U.S.A. 02043

1-800-4-RIELLO
1-800-474-3556
www.riello-burners.com

2165 Meadowpine Blvd.
Mississauga, Ontario,
Canada L5N 6H6