

Power Flame Incorporated

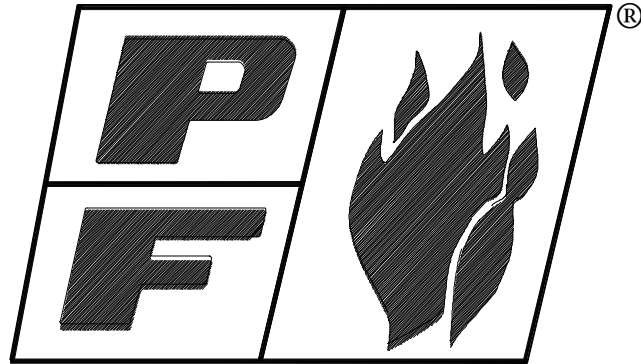

NOVA PREMIX INSTALLATION AND OPERATION MANUAL

THE POWER TO MANAGE ENERGY

2001 South 21st Street, Parsons, Kansas 67357

Telephone: 620-421-0480, Fax: 620-421-0948

Web Site: www.powerflame.com

E-mail: CSD@powerflame.com

1. GENERAL INFORMATION

The NPM NOVA Premix^f burner employs a fully premixed high swirl stabilized combustion head technology to provide proven low NO_x emissions for sub 30 PPM applications and superior flame retention. NO_x emissions lower than 30 PPM can be obtained by running at slightly higher O₂ levels. The NPM burner is designed to fire natural gas and propane against a positive, balanced or negative furnace pressure.

The burner is a self-contained unit comprised of a blower assembly, firing head, ignition system, and flame safeguard control panel. As with any premix burner the excess O₂ operating range is narrower than those of a conventional nozzle mix gas burner. Therefore, during setup care should be exercised in obtaining an excess O₂ reading of not less than 2% or more than 7%.

All Power Flame burners are operationally fire tested at the factory.

2. CAPACITIES & SPECIFICATIONS

<u>Model Number</u>	<u>NPM15-10-24</u>	<u>NPM15-10-120</u>	<u>NPM30A-12-120</u>	<u>NPM30-12-120</u>	<u>NPM50-15-120</u>
Natural/LP Gas Flow X 1,000 BTU/HR	300-720	300-850	390-1,100	480-1,260	825-2,200
Gas Train Size	1"	1"	1-1/4"	1-1/4"	1-1/2"
Blower Wheel Size	7" x 3"	7" x 3"	7" x 3"	8-1/4" x 1-1/2"	9-1/8" x 2-1/2"
Blower Motor HP	1/4"	1/4"	1/2"	1/2"	1"
Motor Voltage	120/60 Hz	120/60 Hz	120/60 Hz	120/60 Hz	120/60Hz
Control Voltage	24 V	120 V	120 V	120 V	120 V
Inlet Pressure To Main Shut-off Cock Inches W.C. Min. / Max.	6.8/14.0	6.7/14.0	7.3/14.0	8.2/14.0	11.6/14.0

3. ACCEPTANCE PROCEDURE

Uncrate burner carefully and check all parts received against your computer generated Bill of Material that is enclosed in the owner's information envelope.

Warranty

The Owners Information envelope packed with the burner contains a Warranty Registration Card. The Warranty Registration Card is also a request form for a Spare Parts List. An on-hand supply of spare parts is highly recommended in case of emergency shutdown. We request that you complete and return the card to Power Flame in the enclosed self-addressed envelope or you can register on line at www.powerflame.com as soon as possible.

4. INSTALLATION

Prior to Installation, Carefully read this Installation and Operation Manual, Review All Charts, Drawings and Diagrams Shipped with the Burner. Installation must be in accordance with all local and national codes including CAN1-B149.1 or B149.2 and Canadian electrical codes for Canadian installations.

- 4.1 If the burner is to be mounted in an existing boiler or furnace, ensure that all fireside surfaces are clean and in good condition. All doors, clean outs, cracks or other openings allowing excess air into the combustion chamber should be tightly sealed, whether the burner is to be fired under positive or negative Combustion Chamber conditions.
- 4.2 The burner can be mounted through a heat exchanger end wall or in the base of the boiler – see Figures 1 and 2. The opening for the burner blast tube should not be less than 6 ¼, 8 ¼, or 10 ¼ inches in diameter (depending on the burner model) to allow easy removal of the burner. The gap between the boiler opening and the blast tube should be sealed with non-asbestos, high temperature rope or Ka-O-Wool. Where a new or replacement combustion chamber lining is to be used the chamber is to be built using 2,300 degree F insulating firebrick or ceramic fiber blanket.

Figure 1. Mounting in Heat Exchanger

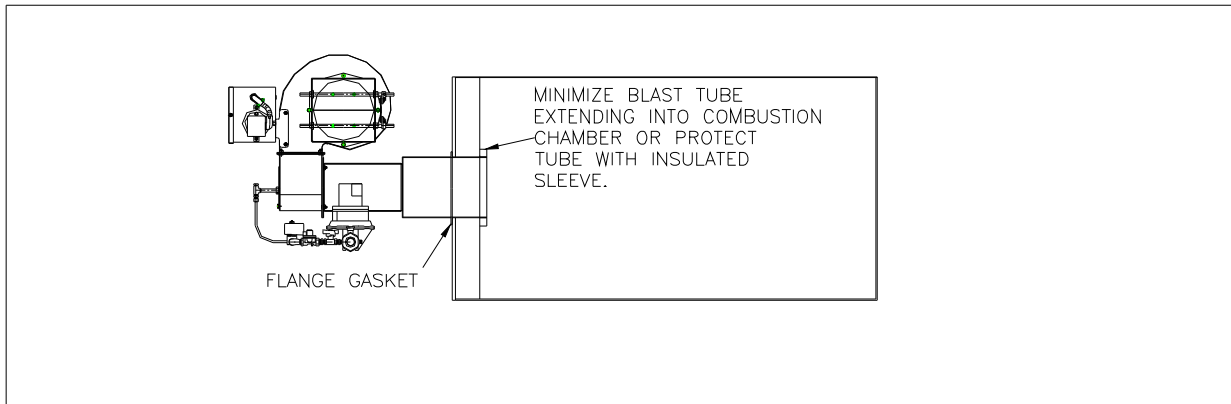
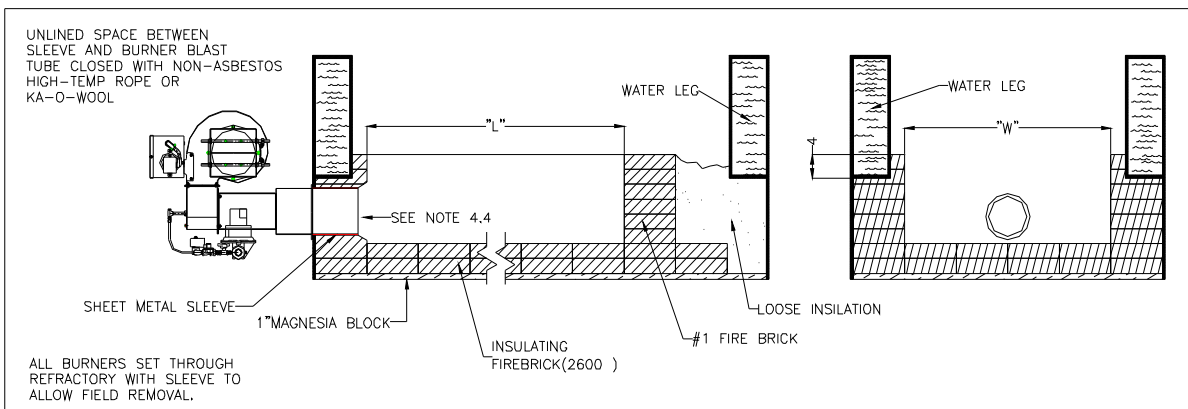

Figure 2. Mounting in Boiler Base



4.3 COMBUSTION CHAMBER SIZING

Table 1. Combustion Chamber Recommended Dimensions

Gas Input MBTU/HR	Width Inches	Length Inches	Gas Input MBTU/HR	Width Inches	Length Inches
450	15	20	1260	23	33
600	16	23	1500	25	38
700	17	25	1800	26	40
850	18	26	2200	28	42

4.4 Whichever method of mounting is chosen, the burner blast tube must be recessed into the front wall surface from 0" to 1/2".

NOTE: Serious Damage To The Burner May Result If The Blast Tube is Extended Into The Combustion Chamber.

4.5 Secure the burner to the heat exchanger or boiler, using the burner-mounting flange. A tight seal between the mounting flange and the front plate should be made using the factory-furnished gasket or ceramic non-asbestos fiber rope.

5 GAS PIPING

5.1 Contact your local gas service company to ensure that adequate gas service is available and to review applicable installation codes for your area. All gas piping installations must be in accordance with NFPA 54, National Fuel Gas Code, Definitions and General Field Recommendations, CGA 3.0, Canadian Natural Gas Installation Code CAN/CGA B149.1 or Propane Installation Code, CGA B 149.2.

5.2 Size the main gas line in accordance with Table 2. The figures shown are for straight lengths of pipe at 0.2" W.C. pressure drop, which is considered normal for low-pressure systems. Note that fittings such as elbows and tees will add to the pipe pressure drop.

Table 2 - Gas Piping Pressure Drop Data

<u>EQUIVALENT LENGTH OF STRAIGHT PIPE IN FEET</u>									
	20	30	40	50	60	80	100	150	200
Pipe Size In Inches	<u>CFH GAS WITH .2" PRESSURE DROP</u>								
1"	300	250	210	190	180	150	135	110	75
1-1/4"	520	425	360	325	300	260	230	190	165
1-1/2"	800	690	560	500	480	410	370	300	260
2"	1700	1400	1200	1100	1000	850	750	600	540
2-1/2"	3000	2500	2100	1900	1800	1550	1375	1100	950

<u>EQUIVALENT LENGTHS OF STANDARD PIPE IN FEET FOR LISTED FITTINGS</u>						
Fitting Type	1"	1-1/4"	1½"	2"	2-1/2"	Nominal Pipe Size In Inches
Std. Tee	5.5	7.5	9.0	12.0	13.5	
Std. Elbow	2.7	3.7	4.5	5.5	6.1	

5.3 Refer to Figure 3 for details of standard gas piping. (Also refer to any additional piping diagrams supplied for this specific unit.)

5.4 Mount leakage test and main gas cocks, main automatic gas valve or combination gas valve/pressure regulator, and auxiliary valves (if required and not factory mounted) per piping diagram or Figure 3 on page 4.

Figure 3. Typical UL Gas Piping Train (Modulating Burner)

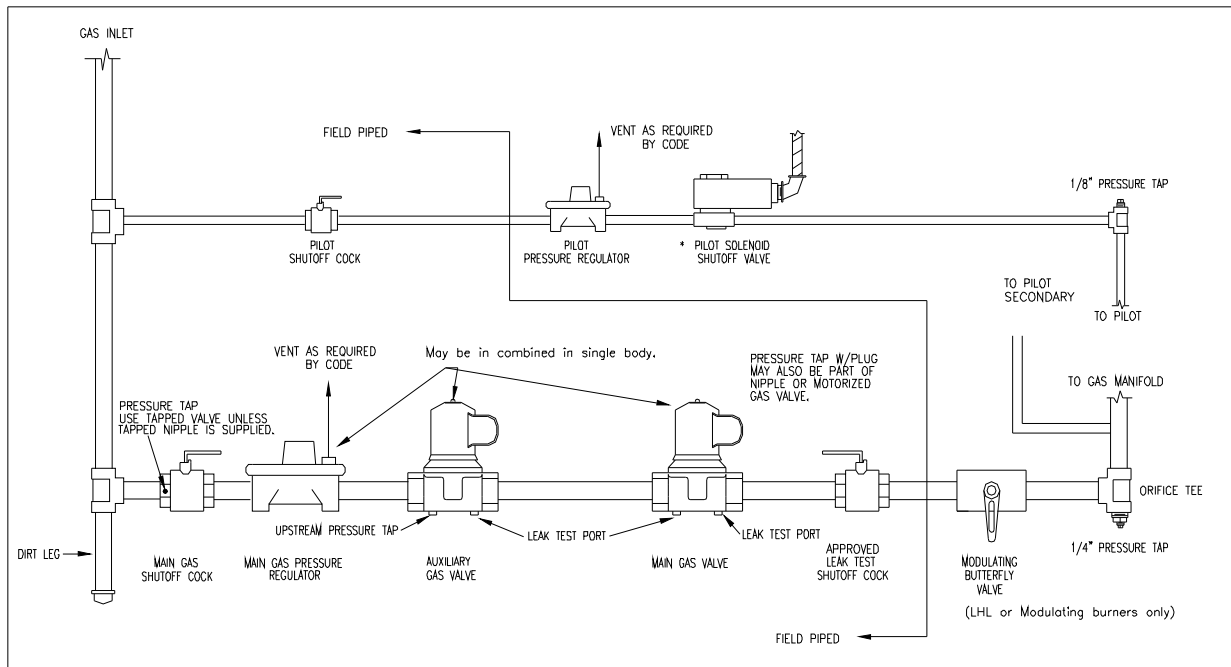

- 5.5 Install pressure regulator (not used with combination gas valve/pressure regulator) directly upstream of main automatic gas valve(s) and fit drip leg and main gas cock upstream of regulator or automatic valve(s).
- 5.6 The pilot line should be piped into the upstream tapped nipple to minimize pilot line piping length. An optional location is in a tapping located on the main shut-off cock. Refer to Figure 3. For ease of servicing the use of a union immediately upstream of the main gas pressure regulator or combination gas valve/pressure regulator is recommended.
- 5.7 Install vent lines from main gas regulator (if used) and diaphragm gas valve where applicable. Vent lines should be run to the outside of the building, terminating clear of windows or fresh air intakes. Outside termination of vent should have a screen to prevent insects from building nests in vent pipe. The vent should terminate in a manner, which will preclude the possibility of water, dirt or other foreign matter from entering the line. Refer to state or local codes for proper venting requirements.
- 5.8 Test gas lines for leaks using a soap solution. Your local gas service company may wish to execute or witness this test. CAUTION – gas pressure above 14" W.C. may damage the standard diaphragm gas shut-off valve. Do not exceed this value when pressure testing lines without first capping off line upstream of main gas cock and pilot take-off.
- 5.9 Check that side orifice size (if used) matches with the burner specification sheet See Figure 4 on page 5. To gain access to orifice, remove orifice tee plug and withdraw spring and orifice. When reinserting or replacing the orifice, ensure that it seats properly inside the tee and reinstall plug.

6 WIRING

- 6.1 Refer to wiring diagram shipped with burner.
- 6.2 Electrical installation must be made in accordance with the NEC, NFPA 70 or Canadian Electrical Code, Part 1 and applicable local codes. If this burner is part of a boiler or furnace package system, check-wiring diagram as supplied by the boiler or furnace manufacturer.

7 START UP

- 7.1 Before attempting a burner start up, thoroughly study and familiarize yourself with the exact sequence of operation and all other details on the specific Primary Safety Control System being used. This information may be found in bulletins supplied with the burner, as well as in technical bulletins covering other components. All of these materials should be used as reference in burner start up and service.
- 7.2 Check boiler water level (if applicable) and all safety interlocks.
- 7.3 Lay out combustion test equipment (see Section 8.4).
- 7.4 Attach gas pressure gauge or manometer to upstream side of main gas cock (0-35" W.C.) and to orifice pressure tap (0-10" W.C.) as well as to pilot gas pressure test tee tapping (0-10" W.C.). Note: On burners using the combination gas valve such as the RobertShaw 7000DERHC the manifold pressure is taken at the 1/8" downstream pressure tapping located on the valve. Refer to Figure 4.

Figure 4. Typical 24 Volt Gas Piping Train (On-Off)

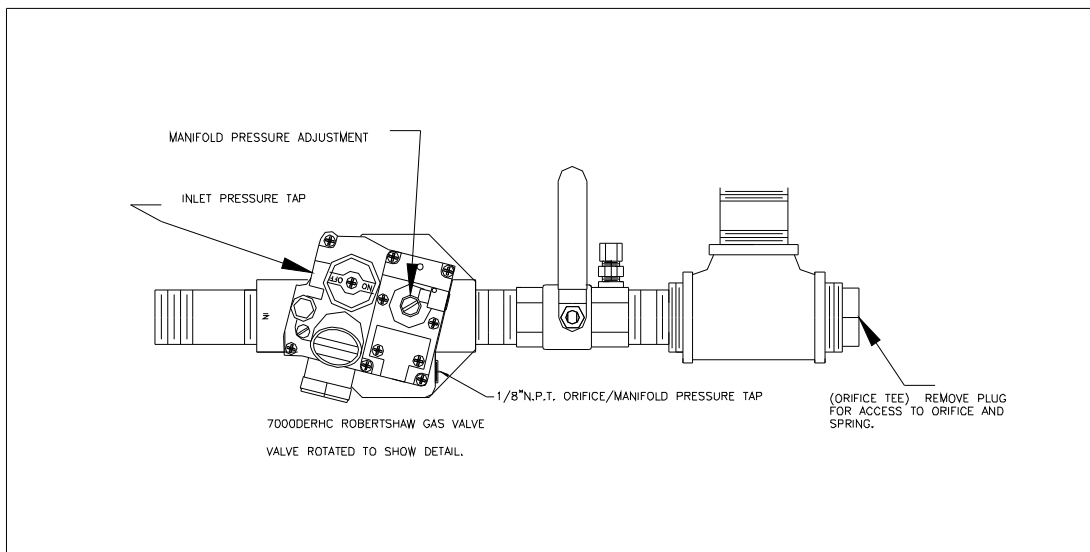

- 7.5 Check the voltage at the disconnect switch to make certain that it matches the voltage indicated on the burner label.
- 7.6 Ensure that all dampers in the flue or stack are fully open.
- 7.7 Install stack thermometer and Flue Gas Analyzer sample line to breaching and draft gauge to combustion chamber test point.

- 7.8 Connect a microammeter or voltmeter to the Primary Safety Control as directed in the PSC manufacturer's instruction bulletin to determine flame detection system values. The meter is normally connected in series with the (SENSE) terminal on the S8680 series control.
- 7.9 With the main and leak test cocks and pilot cock in **OFF** position, turn on the gas cock at meter. Check to make certain that the pressure upstream of main and pilot cocks does not exceed 14" W.C. (1/2 PSIG) – unless special valve train components suitably rated have been furnished (Refer to Burner Specification Sheet). If pressure is acceptable, proceed to next step.
- 7.10 Pilot Ignition

Next check the operation of the gas pilot system. This is a very important part of the start up procedure.

- A. Before attempting burner start up make certain that you are familiar with the operation of the Primary Safety Control and other components being used on this specific application. Refer to Fig. 5 and 5A for pilot spark gap dimensions.
- B. To prepare the pilot for proper operation, it is essential that appropriate adjustments be made on the burner air inlet damper and to the pilot gas pressure. Initial air damper opening should be approximately 1/8 inch open for low high low or modulating type models. On fixed rate burners the air damper may have been factory set to a predetermined opening. The pilot pressure needed will be affected by the damper position. Typical pilot pressure is 0.5" W.C. higher than the static air pressure measured on the pilot during pre-purge for natural and propane gas.
- C. **In many instances, pilot problems relate to gas pressures that are too high or too low, causing the pilot gas mixture to be just outside of the ignition range. The optimum pilot pressure should be determined by adjusting the pilot regulator and finding the minimum and maximum pressure that the pilot lights. Then, set the pilot regulator where the pressure is in the middle of these two pressures.**

Figure 5. Pilot Assembly – Flame Rod Type – Natural Gas/LP Gas - NPM15 – 24 Volt

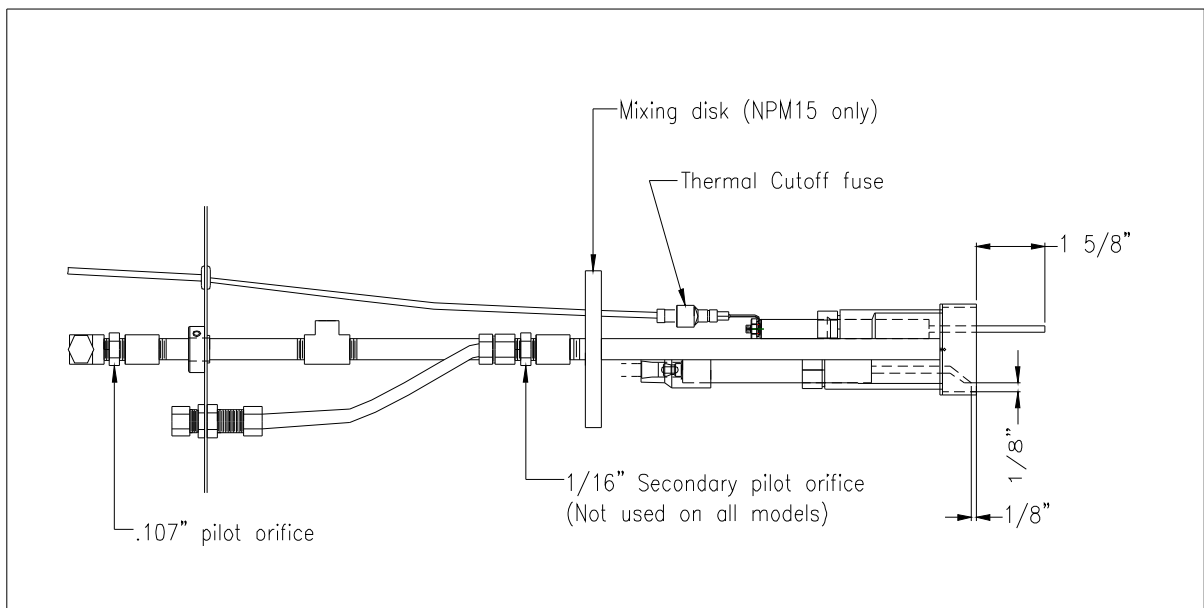
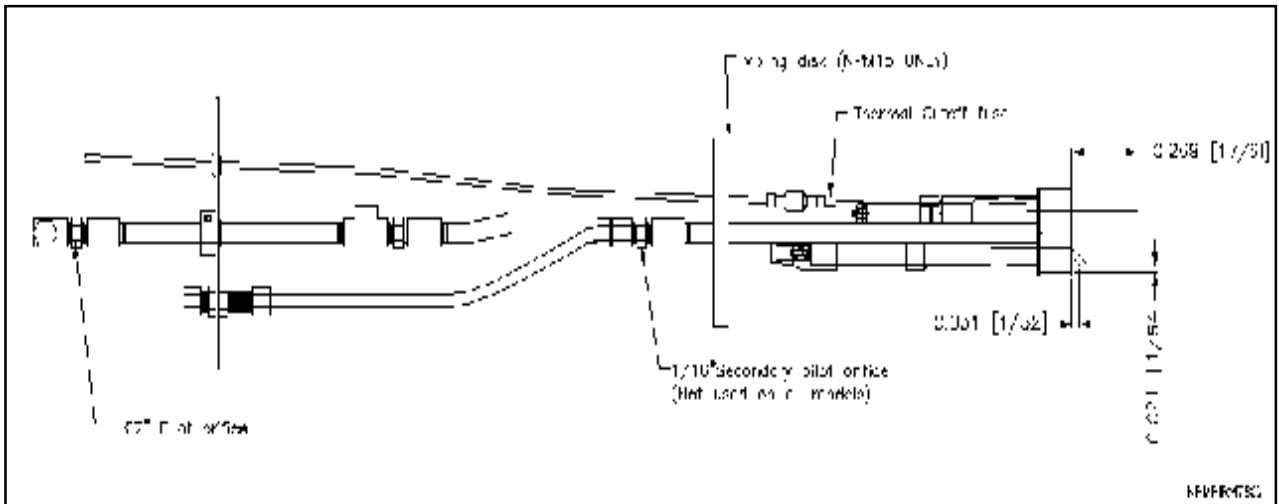

Figure 5A. Pilot Assembly – Flame Rod Type – Natural Gas/LP Gas – NPM15 – NPM50 – 120 Volt



- 7.11 With the leak gas cock closed and pilot gas cock open; turn the burner switch ON. The blower motor will purge the heat exchanger of **any accumulated combustibles**. At the end of the purge cycle, the pilot solenoid valve will energize and spark will be initiated. The pilot will attempt to light for 10 seconds (15 seconds with S8680 control). Adjust the pilot pressure at this time. If the pilot fails to light, lockout will occur. **Note:** If using the S8680 control power must be removed for 60 seconds to allow it to reset.
- 7.12 **Pilot Adjustment and Main Flame Light Off Procedure**
- A. Set the air damper and adjust the pilot regulator gas pressure in order to provide instant pilot ignition, good flame stability, and a strong/steady signal reading. Connect a DC voltmeter or microammeter to the flame safeguard control as appropriate to determine flame detection system signal values. Refer to Table 3.
 - B. Adjust the pilot regulator to obtain approximately 0.5" to 1.0" W.C. pressure at the pilot test port. Note: This pressure varies depending on the damper opening/burner model. The actual pilot gas pressures will typically be 0.5" to 0.1" W.C. above the static air pressure as seen on the gage before the pilot valve opens. Further pressure adjustments may be necessary to obtain the best pilot operating point.
 - C. After attaining the proper pilot flame signal values, cycle the pilot on and off several times in order to ensure reliability (with the gas leak test cock still closed). **Turn Burner Switch Off.**
 - D. Having established pilot reliability, open gas leak test cock.

Table 3. Acceptable Pilot and/or Main Flame Current Readings

<u>CONTROL</u>	<u>FLAME ROD</u>
RM78XX series	1.25-5 VDC
Fireye E series	10 min/20 normal
S8680J	1.5 Microamps

- E. After the burner has completed pre-purge and established a good pilot flame signal reading, the main automatic fuel valve will be energized. As when setting up the pilot, static air pressure will also be evident on the gas manifold. This pressure will increase as the main gas valves open. The main flame should light immediately. If immediate light off does not occur, it is possible that air will need to be purged from the main gas line. Adjust main gas pressure regulator (if used) or combination valve regulator to obtain the desired firing rate pressure.
 - F. Adjust burner as necessary to provide smooth ignition of main flame. If flame signal drops significantly when main fuel valve opens, decrease pilot gas pressure slightly to obtain a reasonably stable flame signal value.
 - G. If required, select and install the main orifice that corresponds to the desired firing rate, see table 4 on page 9. Ensure that the airflow setting provides the correct CO₂ or O₂ levels and other combustion values at the proper firing input rates. Generally accepted values for natural gas are 8-1/2 to 10% CO₂ or 5-1/2 to 3% O₂. Equivalent CO₂ readings on propane gas are 10 to 11-1/2% CO₂ or 5-1/2 to 3-1/2 % O₂. It is important that the CO (carbon monoxide) level is checked and held at 0% or minimum (typically under 100ppm or 0.01%). Check with the local gas utility and any other authorities having jurisdiction before making final burner adjustments.
- 7.13 Conduct all applicable test procedures shown in the Primary Safety Control manufacturer's bulletins included with the burner. Set and check operation of low and high gas pressure switches (if applicable), all burner and heat exchanger controls, and operating devices. Check blower airflow proving switch by first closing main gas cock and disconnecting motor lead wire. A properly adjusted air switch should open within 3 to 4 seconds when the power is removed from the motor.
- 7.14 Clean up area around the burner and review operating procedures and instructions with owner and/or operator.
- 7.15 Post Installation and Operating Instructions close to the burner in clearly visible position for future reference.

8. COMBUSTION ARRANGEMENT REQUIREMENTS

8.1 The NPM burner has been designed to fire with high combustion efficiency into combustion chambers with positive, balanced or negative pressures using natural or PROPANE gas only.

8.2 In order to fire efficiently, the burner requires an adequate supply of combustion air. Ventilation to any enclosed area should be provided on the basis of 1/2 square inch of opening for each 1,000 BTU/HR input. This excludes the requirement for any other fired equipment in the area. Consult NFPA 54 for combustion air requirement. The enclosed area should not become excessively hot and under no circumstances should be under a negative pressure.

The burner should be initially set up and serviced at regular intervals (preferably at the beginning of and mid way through high use periods) by a trained serviceman using the proper test instruments. Failure to maintain the correct burner settings may result in inefficient gas consumption, premature wear of burner and heat exchanger components, uncontrolled combustion.

8.3 Approximate gas flow rates and corresponding pressures are shown in Table 4 for natural gas and propane gas. These rates/pressures represent approximately 5% excess O_2 at 0.0" W.C. furnace pressure. Since the amount of excess air will affect the actual manifold pressure/rate, verification of the exact firing rate should be confirmed by clocking the gas meter and applying the appropriate correction factor.

8.4 The necessary test instrumentation are:

- a. O_2 analyzer (electronic or Fyrite absorption system)
- b. CO indicator (Monoxor or similar)
- c. Stack thermometer
- d. Draft gauge or inclined manometer
- e. U-tube manometer or calibrated 0-10" and 0-35" W.C. pressure gauge
- f. Combination volt/ammeter
- g. D.C. Micro-Ammeter

Table 4. Manifold Pressure Chart. The pressures shown represent a zero furnace pressure. Actual furnace pressure must be added to these pressures to obtain the total pressure needed at a given firing rate.

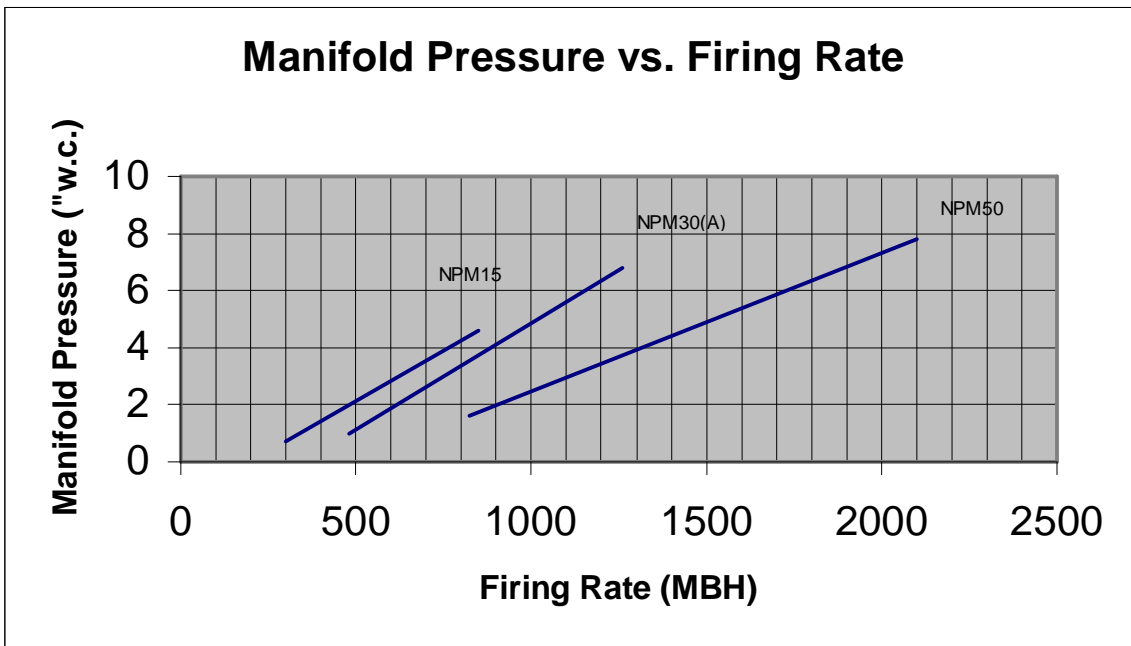

9. SERVICE/MAINTENANCE SUGGESTIONS

9.1 Burner fails to start:

1. Bad fuse or switch open on in-coming power source, or motor overload tripped out.
2. Control circuit has an open control such as operating, limit or low water cut-off.
3. Push the reset button on the motor or open the power circuit to the primary safety control.
4. Loose or faulty wiring. Tighten all terminal screws. Check wiring, against wiring diagram furnished with burner.

9.2 Burner motor runs, but pilot does not light

1. Be sure gas is turned on at meter and pilot cock is open.
2. Place hand on pilot valve to physically confirm it is opening. Check gauge at tee in pilot line for gas pressure and prompt opening of pilot valve. The typical pilot pressure will be 0.5" w.c. above the static air pressure.
3. Check visually or by sound for spark arcing. Verify that electrode is not cracked or shorted.
4. Refer to section 7.10 on pilot checking procedures.
5. Check air switch and be sure its circuit closes during start.
6. Check continuity through "Thermal Cutoff Fuse" located between flame rod and flame rod wire.
7. Verify the spark gap is correct. Refer to Figure 6.
8. Check for carbon fiber build-up between electrode tip and pilot body.
9. Check inlet gas pressure. On burners using a low gas pressure switch the inlet gas pressure must be at least 6.5" W.C.

9.3 Burner motor runs, pilot lights, but main gas valve does not open

1. Check flame signal. If signal is low, adjust pilot gas pressure and air settings for improved readings.
2. Check main gas valve electrical circuit.
3. Shut-off cock or leak test cocks not open.
4. Shut-off knob on combination valve not turned "On".
5. Defective main valve.

9.4 Occasional lockouts for no apparent reason

1. Re-check microamp readings. If insufficient, check gas pressure and air damper setting. Check electrode setting. If flame signal is low, flame rod may have to be re-positioned.
2. Check ignition cable and electrode porcelain for damage or breaks, which could cause short.
3. Check for loose or broken wires.

9.5 Burner will not start – even though burner had never failed before or had been running on normal cycling without failure.

1. Operating Control circuit open.
2. Defective control or loose wiring.
3. Limit circuit open.

9.6 Burner is operating with rough combustion noise.

1. Excess O₂ is too high. Verify that damper is not open too far.

9.7 The burner must be periodically inspected to ensure safety and performance. All maintenance must be performed with the main electrical power off and the main gas shutoff valve set in its off position.

1. Inspect blower inlet screen and clean any buildup of lint.
2. Inspect blower wheel blades and clean any buildup of dirt.
3. Inspect ignition electrodes and wiring for any cracks that may cause shorting.
4. Oil the blower motor at the manufacturer's recommended intervals.
5. Verify that the pilot electrode is still within specifications (set per drawing in this manual).
6. Verify the proper operation of the Primary Safety Control, airflow switch, and operating controls.
7. Check safety shutoff gas valves for gas tightness.

9.8 In the event of extended shutdown, the main power should be turned off and the main manual gas shutoff valve should be closed. (Off position)

An additional source of information relative to trouble shooting can be found in the Primary Safety Control Manual supplied with the burner.

BURNER START UP INFORMATION & TEST DATA

The following information shall be recorded for each burner start up:

Power Flame Model _____ Job No. _____ Serial No. _____

Installation Name _____ Start Up Date _____

Start Up Contractors Name _____ Phone _____

Name of Technician doing Start Up _____

Type of Gas: Nat. LP Other

Gas Firing

Gas Pressure at Train Inlet

Burner in Off Position _____ "W.C.
 Low Fire _____ "W.C.
 High Fire _____ "W.C.

Combustion Efficiency

Low Fire _____ %
 High Fire _____ %

Gas Pressure at Firing Head

Low Fire _____ "W.C.
 High Fire _____ "W.C.

Gas Pressure at Pilot Test

Tee _____ "W.C.

Flame Signal Readings D.C. Volts

Micro Amps

Pilot _____
 Low Fire _____
 High Fire _____

CO₂ or O₂ (Specify)

Low Fire _____ %
 High Fire _____ %

CO

Low Fire _____ PPM
 High Fire _____ PPM

Input Rate

Low Fire _____ BTU/HR
 High Fire _____ BTU/HR

Overfire Draft

Low Fire _____ "W.C.
 High Fire _____ "W.C.

NO_x (Corrected to 3% O₂)

Low Fire _____ PPM
 High Fire _____ PPM

Stack Outlet Test Point Draft

Low Fire _____ "W.C.
 High Fire _____ "W.C.

Net Stack Temperature

Low Fire _____ ° F
 High Fire _____ ° F

BURNER START UP INFORMATION & TEST DATA

Control Settings

Gas

Operating control cut out setting _____
 Operating control cut in setting _____

Low gas pressure switch _____ "W.C."
 High gas pressure switch _____ "W.C."

Limit control cut out setting _____
 Limit control cut in setting _____

Other _____

Power supply: Volts _____ Ph _____ Hz _____
 Control circuit: Volts _____
 Blower motor amps at high fire _____

Other _____

Operation Checklist

Checked For Proper Operation Of:	Yes	No		Yes	No
Low water cut off	_____	_____	Barometric damper	_____	_____
High water cut off	_____	_____	Boiler room combustion air & ventilation provision correct	_____	_____
Flame safeguard control ignition failure	_____	_____	Oil tank vent system correct	_____	_____
Flame safeguard control main flame failure	_____	_____	All oil lines checked for leaks	_____	_____
Burner air flow switch	_____	_____	All gas lines checked for leaks	_____	_____
Induced draft fan controls	_____	_____	Gas lines & controls properly vented	_____	_____
Over fire draft controls	_____	_____	Other system components (specify)	_____	_____
Fresh air damper end switch	_____	_____		_____	_____

Notified _____ of the following system deficiencies: _____
