

SUPERIOR **BOILER**

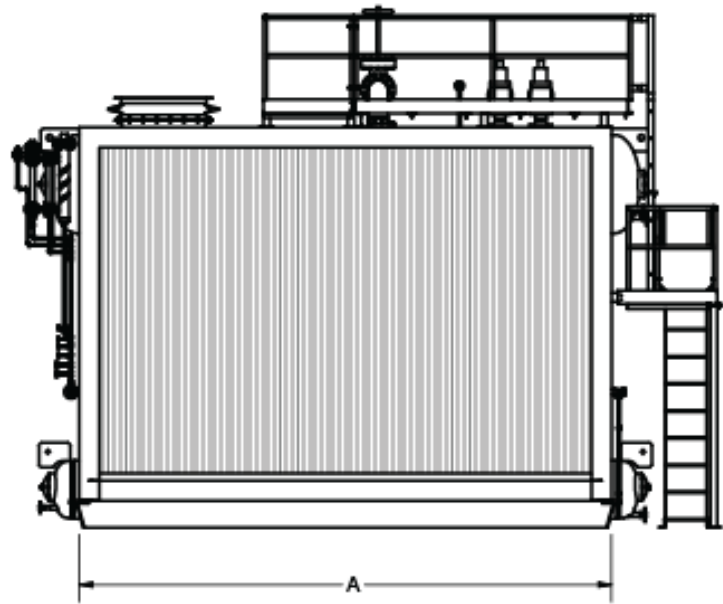

APPALACHIA **A-TYPE WATERTUBE BOILER**

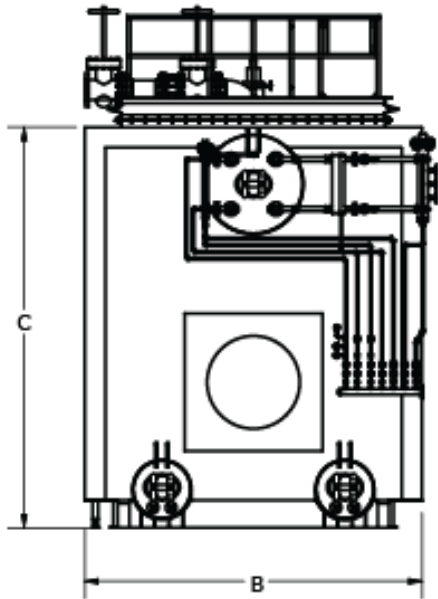

- ✓ Design pressure up to 1,200 psig
- ✓ Sizes from 30,000 - 300,000 lb/hr
- ✓ Capable of burning natural gas, fuel oil, digester gas, hydrogen, & various other gaseous fuels
- ✓ Radiant type superheaters up to 900° F
- ✓ Gas outlet configuration: top
- ✓ Available as a Modular Boiler System
- ✓ Offered in the patented DFW design

| | LENGTH (A) | WIDTH (B) | HEIGHT (C) |
|---------------|------------|-----------|------------|
| 30,000 LB/HR | 173 in. | 114 in. | 162 in. |
| 40,000 LB/HR | 202 in. | 120 in. | 162 in. |
| 50,000 LB/HR | 210 in. | 138 in. | 168 in. |
| 60,000 LB/HR | 232 in. | 138 in. | 168 in. |
| 70,000 LB/HR | 247 in. | 148 in. | 178 in. |
| 80,000 LB/HR | 266 in. | 148 in. | 178 in. |
| 90,000 LB/HR | 296 in. | 148 in. | 178 in. |
| 100,000 LB/HR | 291 in. | 148 in. | 184 in. |
| 125,000 LB/HR | 364 in. | 148 in. | 184 in. |
| 150,000 LB/HR | 424 in. | 150 in. | 194 in. |
| 175,000 LB/HR | 454 in. | 150 in. | 202 in. |
| 200,000 LB/HR | 490 in. | 155 in. | 202 in. |
| 250,000 LB/HR | 514 in. | 170 in. | 216 in. |
| 300,000 lb/hr | 528 in. | 182 in. | 274 in. |



When it comes to boilers, flexibility and resourcefulness are king. Superior Boiler and our team of Superior Problem Solvers tackle your most complex boiler challenges so you can get down to business and keep the world running. We design and manufacture a complete line of boilers for all market segments. We build to our customers' exact standards at our facility in Hutchinson, KS, and our boilers are installed all over the world.

